

Note:

The KITBOT Chassis is designed to be configurable to function as either a "wide" or "long" setup. As such, "out of the box" it comes as a 38" x 38" chassis.

Please modify it accordingly to adhere to FIRST rules.

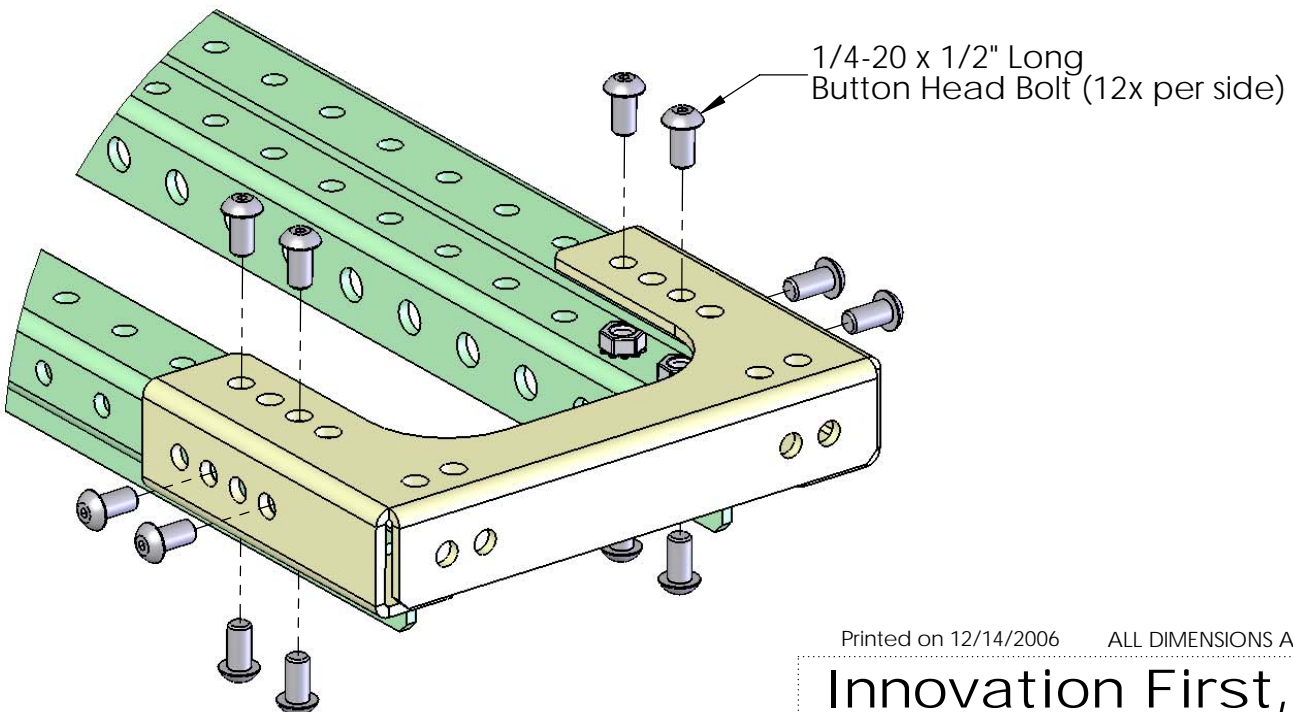
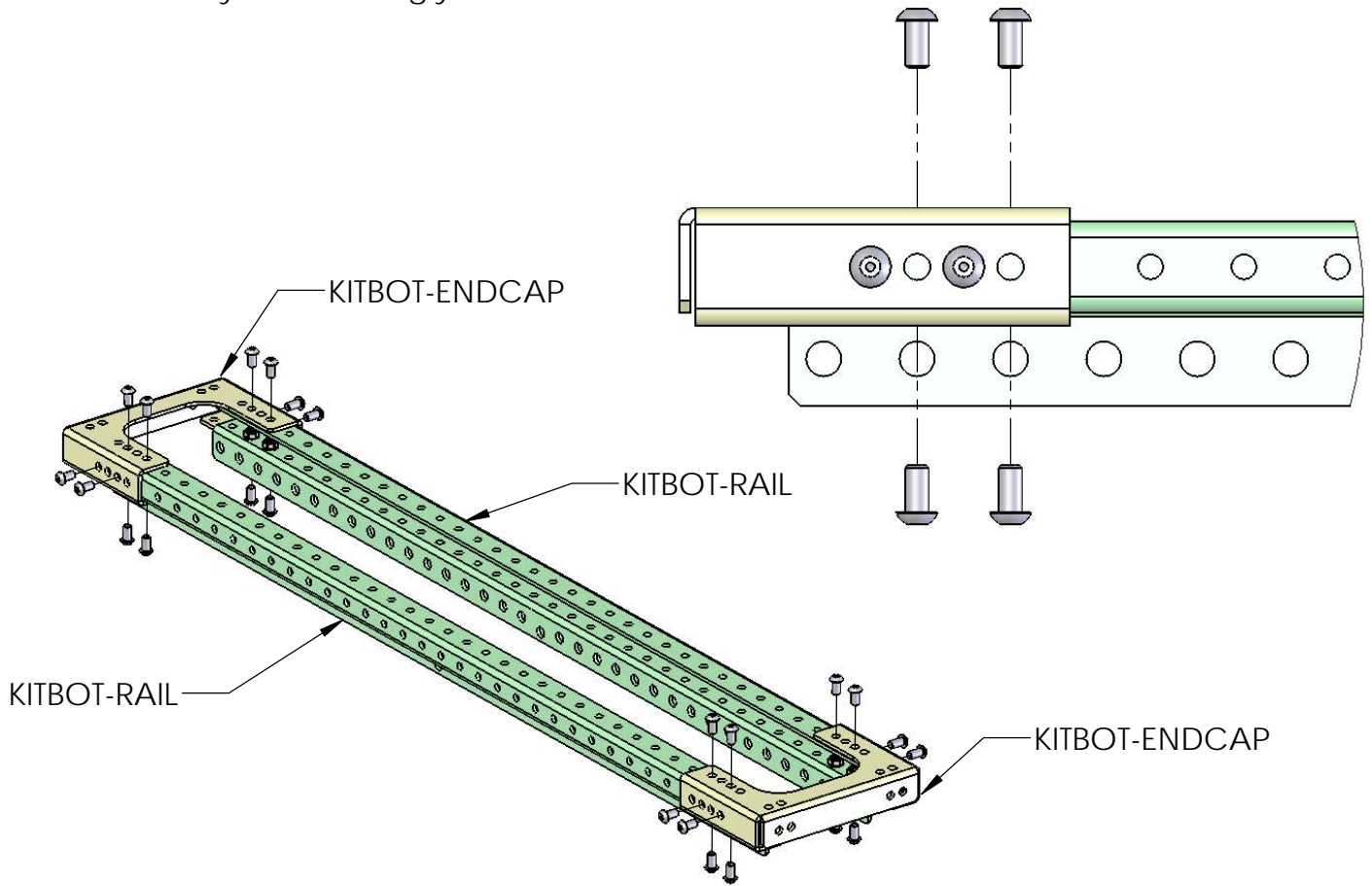

Assemble Chassis Module as shown above.
(2) Assemblies required per Robot.

All bolts should be inserted into 1/4-20 KEPS Nuts.

Printed on 12/14/2006 ALL DIMENSIONS ARE IN INCHES.

Innovation First, Inc.
Chassis Module Assy

Part Number
CHASSIS-ASSY

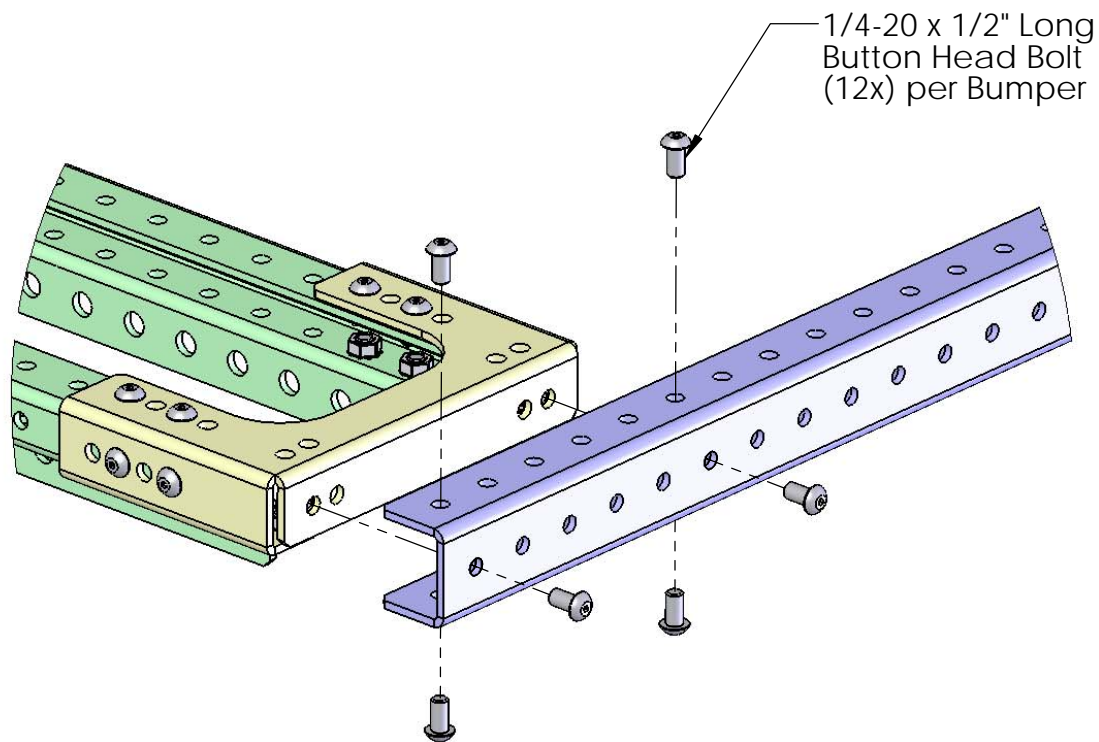
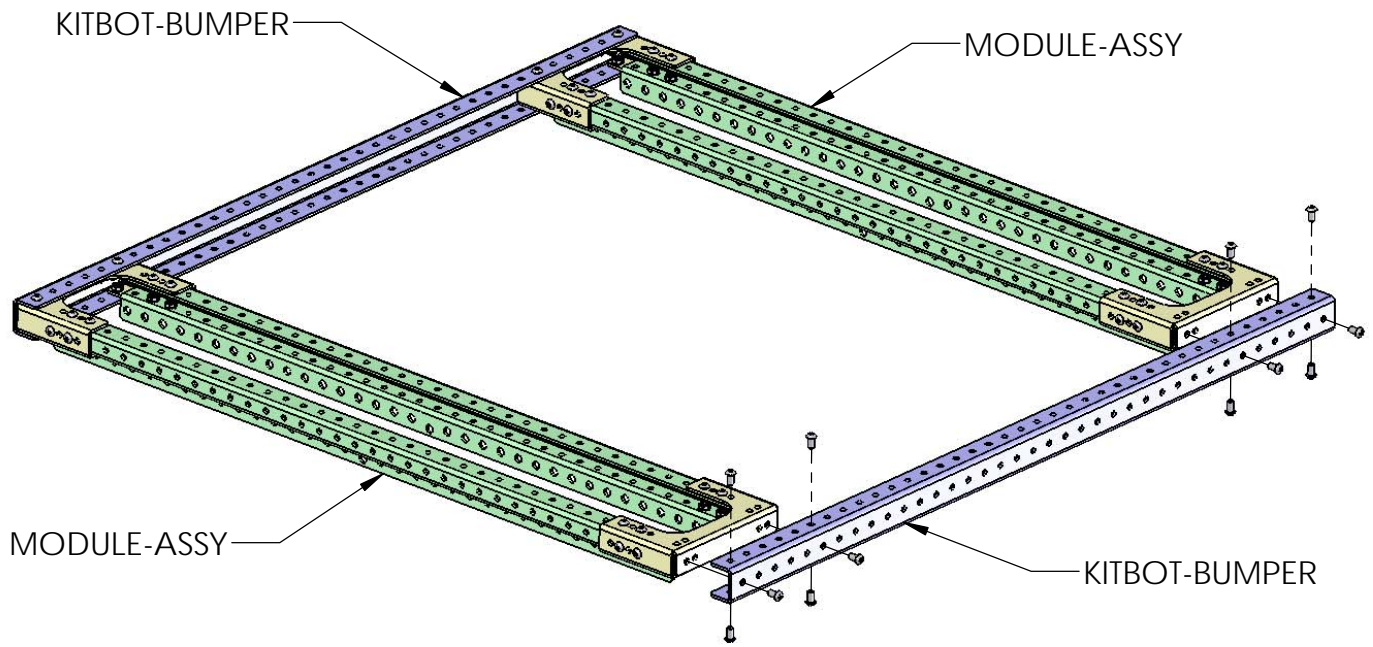

Innovation First, Inc.
Bumper Attachment

Part Number
CHASSIS-ASSY

All Bolts should be inserted into 1/4-20 KEPS nuts.

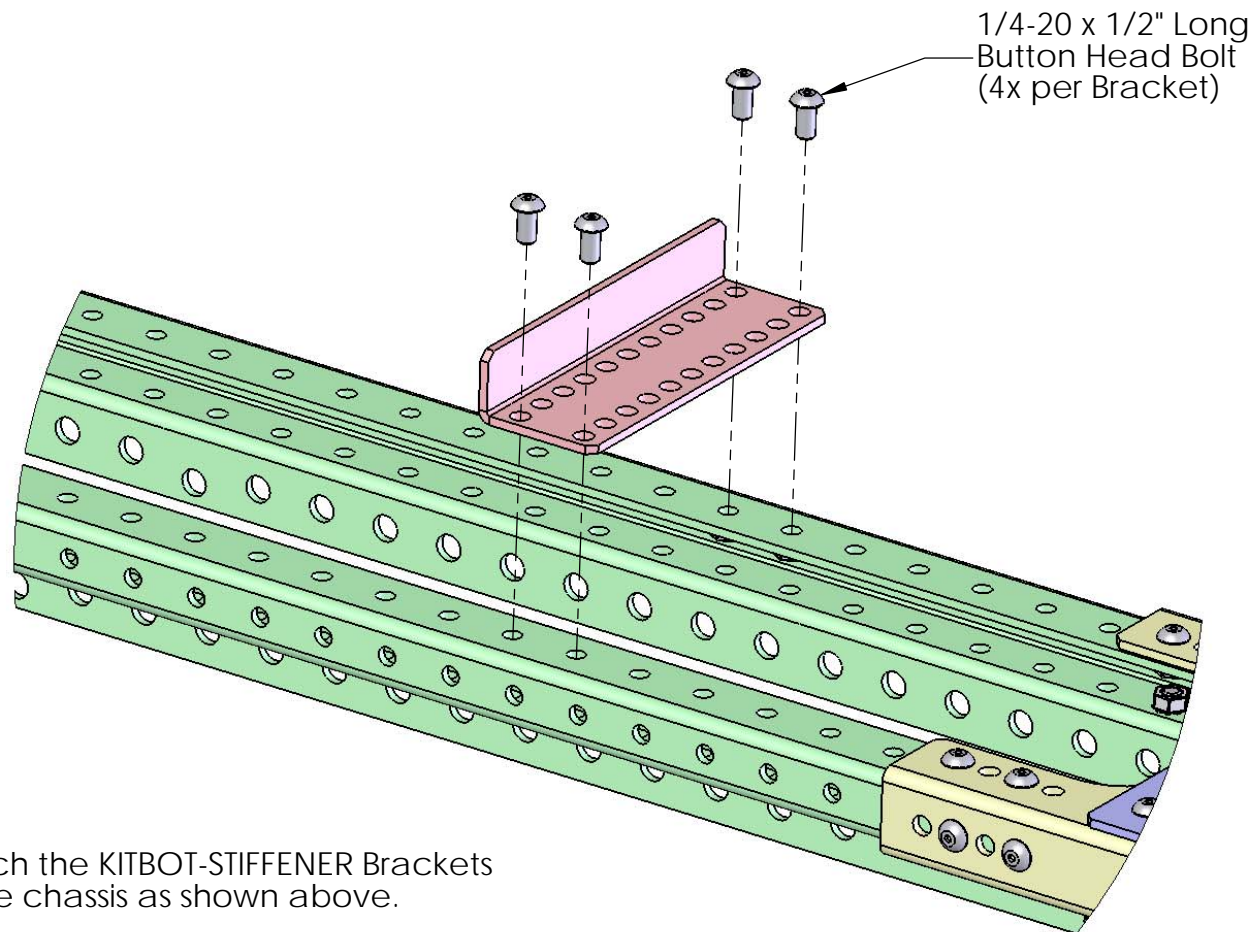
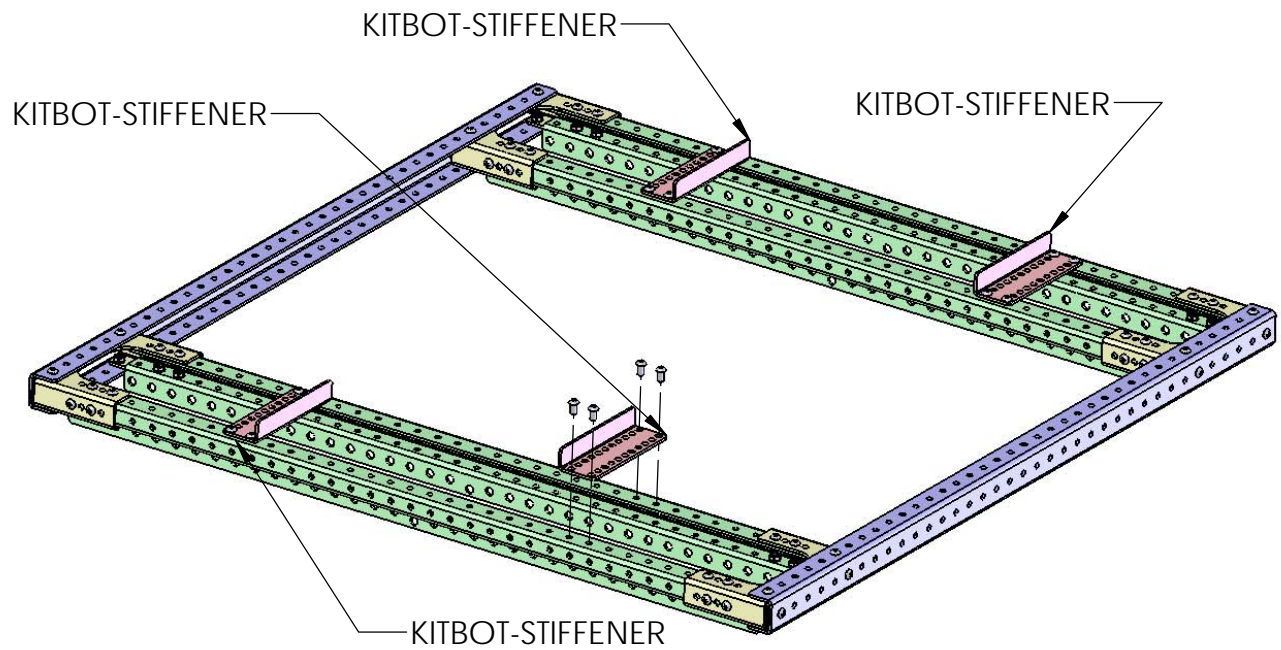

Attach the KITBOT-STIFFENER Brackets to the chassis as shown above.

Ensure the Brackets will not interfere with drivetrain chain.
(4x) Brackets per Chassis.

All Bolts should be inserted into 1/4-20 KEPS nuts.

Innovation First, Inc.
Stiffener Attachment

Part Number
CHASSIS-ASSY