

Sensor Accessories

Motor 393 Integrated Encoder Module

This product replaces the plastic cap on the back of a VEX 2-Wire Motor 393 with a quadrature encoder. Install this product to receive direct feedback from the motor. This encoder provides information on how fast the motor is going, how far it has travelled, and what direction it is moving.

INSERT THIS PAGE
at the **back of the**
Sensor Chapter in your
VEX Inventor's Guide.

Installation

These instructions will show how to install (1) 276-1321 onto (1) 276-2177 2-Wire Motor 393 (not included).

1. Using a #1 Phillips Screwdriver, remove the (4) screws holding on the green plastic motor cap, then remove the cap.

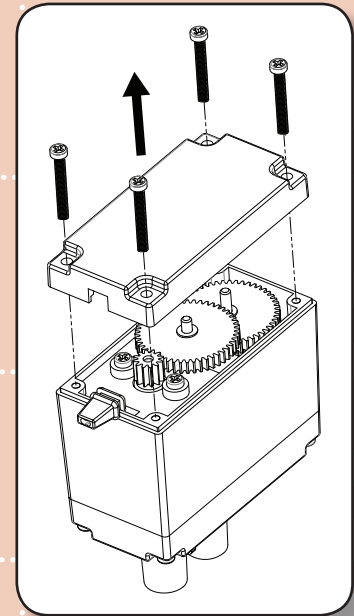

2. Remove the first cluster gear (as shown) and replace it with the Gear with the White/Black Encoder Wheel from the kit. Ensure the gear meshes with its two mating gears, and that the steel axles are still fully inserted into the plastic motor housing.

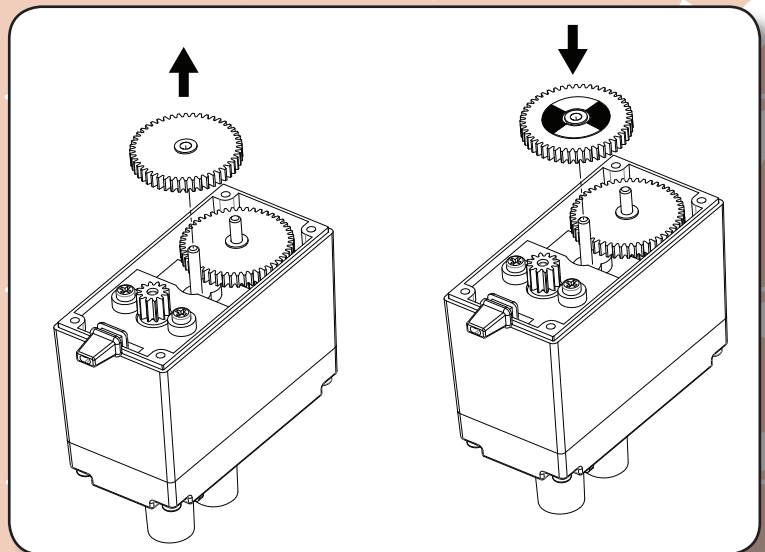

Limited 90-day Warranty

This product is warranted by VEX Robotics, Inc. against manufacturing defects in material and workmanship under normal use for ninety (90) days from the date of purchase from authorized Innovation First dealers. For complete warranty details and exclusions, check with your dealer.

VEX Robotics, Inc.
1519 IH 30 W
Greenville, TX 75402

09/11

For More Information, and additional Parts & Pieces refer to:
www.VEXrobotics.com

Motor 393 Integrated Encoder Module, continued

3. Place a new Motor Encoder Cap onto the 393 motor as shown (note the orientation). Ensure both steel axles slide into the holes protruding from the encoder cap.
4. Using a #1 Phillips Screwdriver, secure the cap with (4) Cap Mounting Screws (included in the kit).
5. Spin the motor by hand to ensure there is no binding in the geartrain. (Test it so you know you did everything correctly).

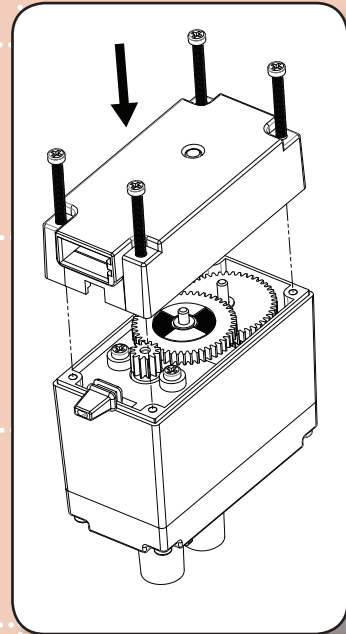

Usage Instructions

PROGRAMMING REQUIRED!

This product does not work “out of the box.” To utilize a VEX Integrated Encoder Module consult the help files from your programming software provider.

This Integrated Encoder Module communicates with the VEX Cortex Microcontroller via I2C. VEX I2C devices can be “daisy chained” together such that multiple devices can be controlled (in a chain) from one Microcontroller – this is why each Integrated Encoder Module has (2) connectors – one I2C input, and one I2C output. Simply connect your chain of encoders to the I2C port on the VEX Cortex Microcontroller via a 4-wire cable. VEX uses a dynamic method of I2C addressing & configuration, so the encoders should link right up.