

VEX 75 MHz Signal Splitter

The Vex Signal Splitter is a 'No Brainer'. This control component can be used to drive up to (6) PWM devices, including VEX Continuous Rotation Motors & VEX Servos. Since this device is capable of directly taking the signal output from the VEX 75 MHz Receiver Module and driving motors, it is now possible to build robots without a VEX Microcontroller.

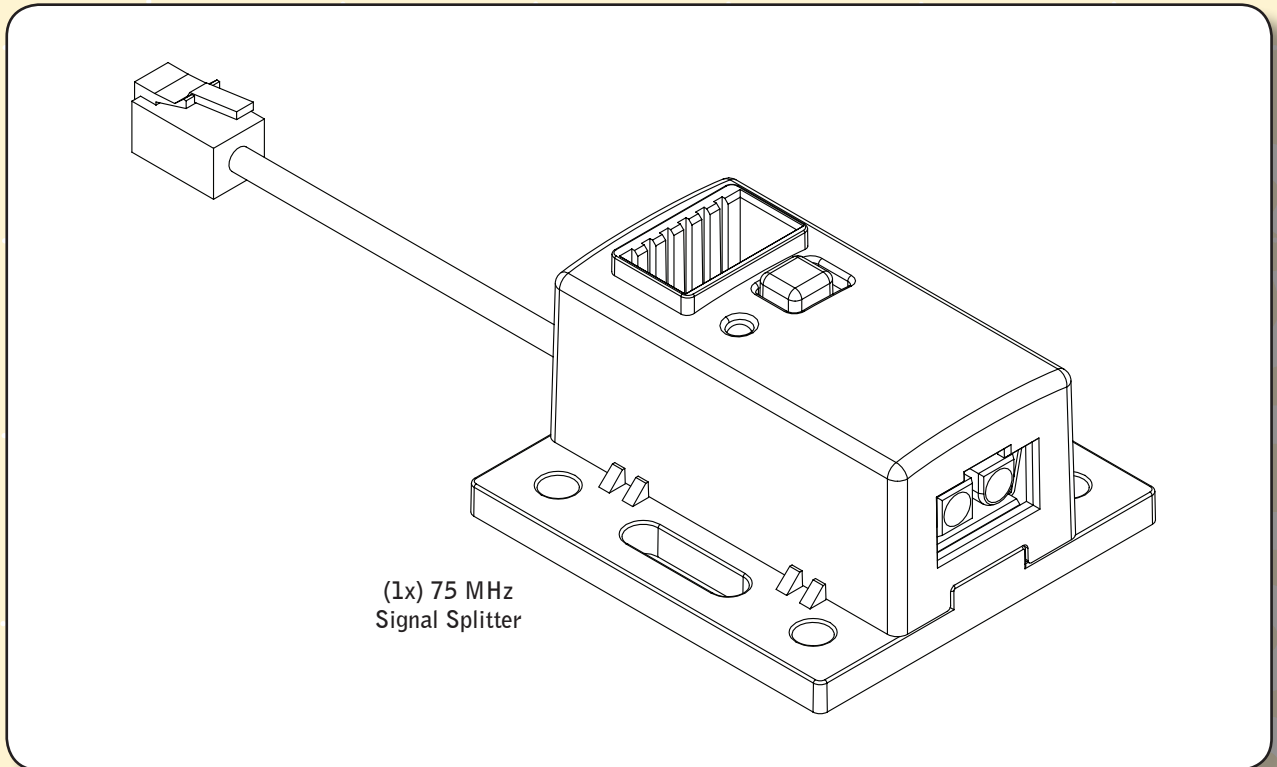

This module is not programmable; it directly maps the input channels to the output motor ports and can not be changed. It acts as a "dumb" replacement for the VEX Microcontroller.

Note: This module requires the VEX 75 MHz Transmitter & Receiver Kit (TX/RX), as well as a 7.2V Battery to operate.

Limited 90-day Warranty

This product is warranted by VEX Robotics, Inc. against manufacturing defects in material and workmanship under normal use for ninety (90) days from the date of purchase from authorized Innovation First dealers. For complete warranty details and exclusions, check with your dealer.

VEX Robotics, Inc.
1519 IH 30 W
Greenville, TX 75402

4/10

For More Information, and additional Parts & Pieces refer to:

www.VEXRobotics.com

Control Accessories

VEX 75 MHz Signal Splitter, continued

Mount the VEX 75 MHz Signal Splitter securely to the robot using standard VEX hardware (not included).

Connect the VEX 75 MHz Signal Splitter to the VEX Receiver using the pigtail Signal Cable. Provide power to the unit by hooking up a 7.2V VEX Robot Battery Pack, or a 7.2V VEX Battery Holder to the power connector.

Plug Vex Continuous Rotation Motors or VEX Servos into the Motor Ports (numbered 1-6). Note: Vex Motors & Servos have a "keyed" connector and will only insert in one (correct) orientation.

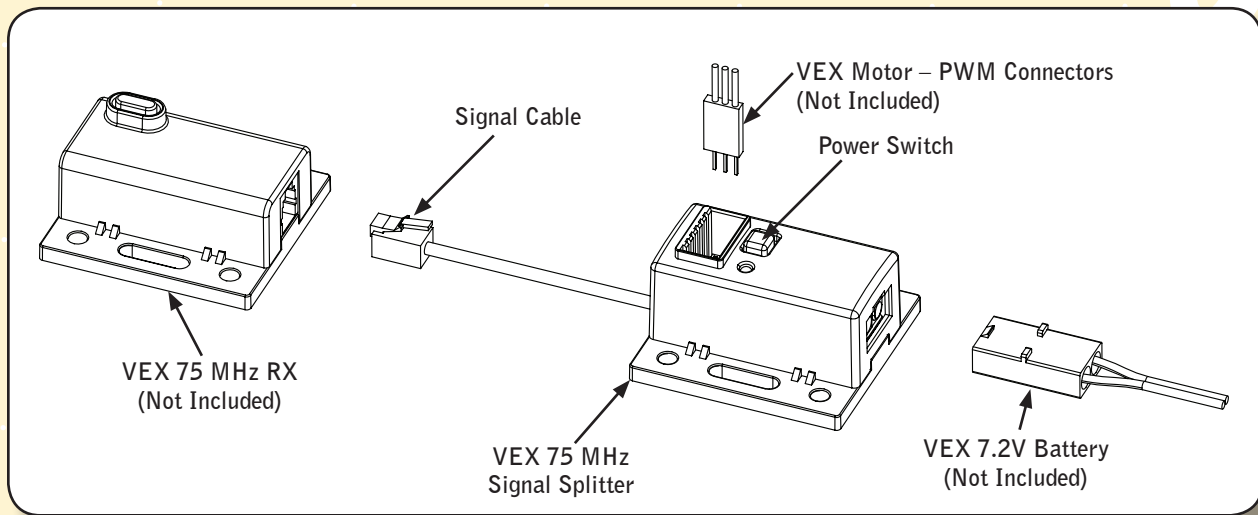

Turn "On" the Power Switch on the top of the VEX 75 MHz Signal Splitter module before operation.

The Motor Ports (# 1-6) correspond to the Channels (# 1-6) of the VEX 75 MHz Transmitter. Example: Anything connected to Motor Port # 1 will be controlled by TX Channel # 1.

There is no option for programming or configuration other than the features integrated into the 75 MHz Transmitter unit.