

Elevation Practice Kit

Introduction

The VEX Robotics Competition *Elevation* Practice Kit contains everything a team needs to prototype and practice *Elevation*. This kit includes low cost versions of the *Elevation* field elements, as well as a sampling of *Elevation* game objects. Using the items in this kit will allow a team to get a feel for the *Elevation* field without actually possessing a full playing field.

What's Included

The *Elevation* Practice Kit includes the following:

- (1) Cardboard 3" High Goal
- (1) Cardboard 9" High Goal
- (1) Cardboard 15" High Goal
- (1) Cardboard 21" High Goal
- (1) Cardboard Platform Assembly
- (1) Official Elevation Autoloader
- (10) 3" Red Cubes
- (10) 3" Blue Cubes
- (1) 10.5" Bonus Cube



Note: Assembling the components of this kit requires the use of 2" wide tape. This tape is not included in the kit; use any 2" wide tape. (ex. Clear packaging tape works well.)

Cardboard Platform Assembly Instructions

The *Elevation* Cardboard Platform Assembly consists of (5) pieces, a box which forms the central platform, and (4) ramp pieces. The first step in building the platform assembly is to fold the central platform box as shown in step 1 below.

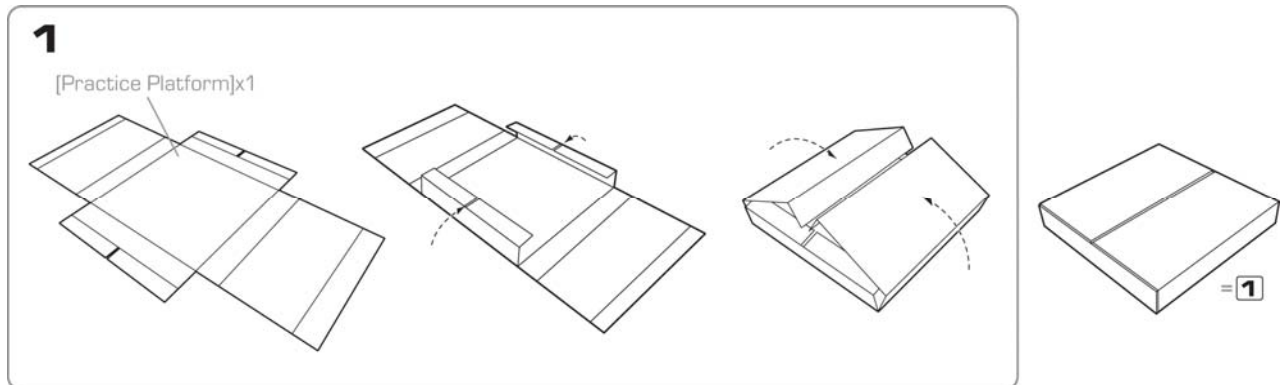

Cardboard Platform Assembly Instructions cont

The second step in assembling the cardboard platform assembly is to fold and tape the (4) ramp pieces, as shown below in step 2. Repeat this step (4) times.

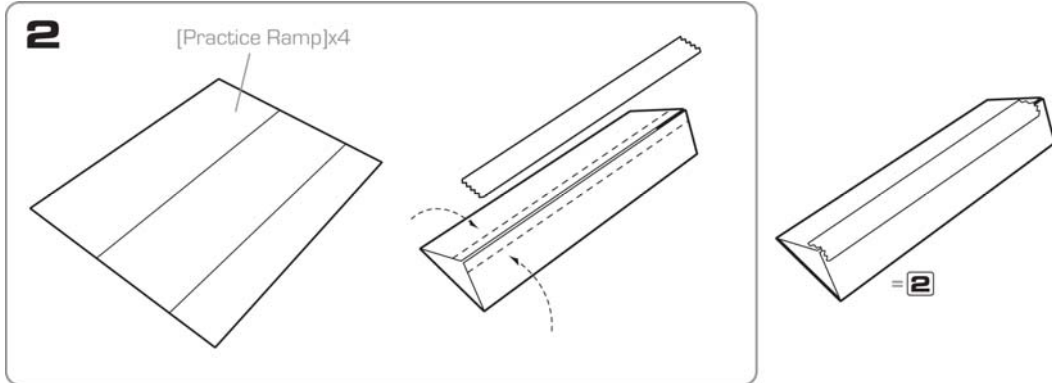

Once the (4) ramps are assembled attach the bottoms of the ramps (from step 2) to the bottom of the platform (from step 1) using tape as shown below in step 3.

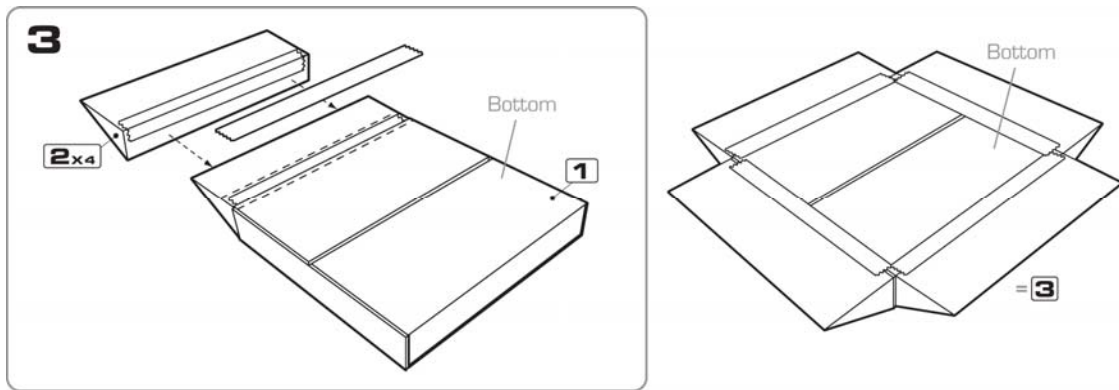

Now flip the assembly from step 3 over, and tape the top of the (4) ramps to the top of the platform, as seen below in step 4.

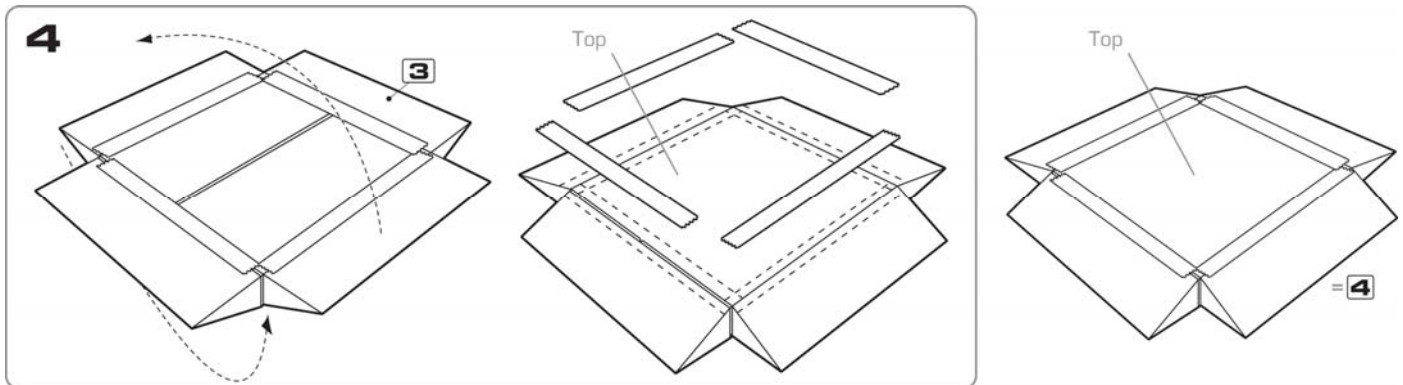

Cardboard High Goal Assembly Instructions

The VEX Robotics Competition *Elevation* Practice Kit comes with (4) Cardboard High Goals, one of each of the (4) different sizes. These goals are identical in cross section, and only differ in height. They are all assembled in the same manner. To assembly a Cardboard High Goal, fold it and tape it as shown in step 5 below.

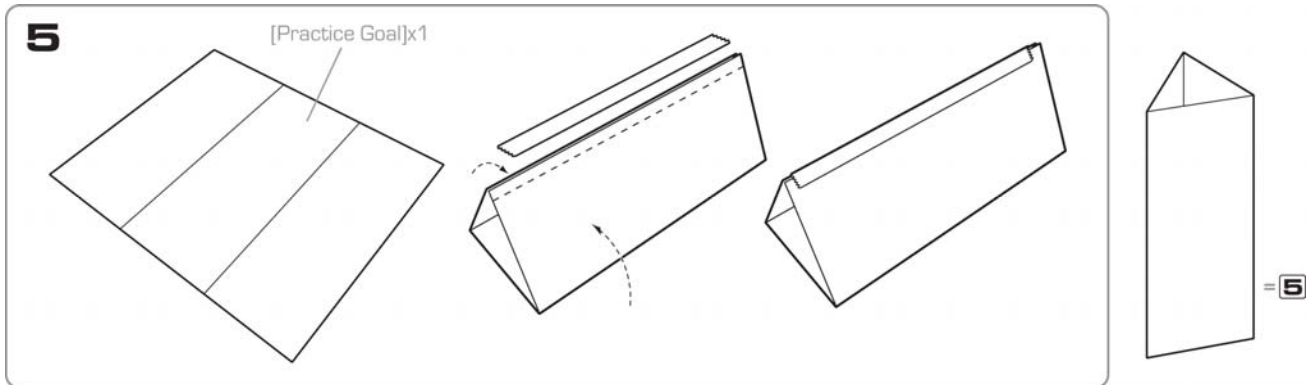

Robot Design & Build Tips

Now that the components of your practice kit are assembled you can begin designing a robot to play *Elevation*. Here are a few tips to remember as you prototype and design:

- Know the rules – if you don't know the *Elevation* rules, you can't follow them. Make sure you're your team reads through the *Elevation* manual and is familiar with all the rules & regulations of the VEX Robotics Competition.
- Design is an iterative process – keep revising & improving your robot until it dominates the competition. Don't be afraid to experiment to see what works best.
- Simplify! Often a simpler mechanism is more effective and reliable than a complex mechanism.
- Try to design one mechanism which can accomplish multiple functions or tasks.
- Design with a factor of safety – leave some margin for error in your robot's performance. If you want to be able to put a cube in the 21" High Goal, ensure your robot can reach higher than 21", maybe it would be good to reach a few inches higher, to leave some margin for error.
- Consider your robot's stability and center-of-gravity, especially because the center platform has inclined ramps on it. Plan for this from the beginning, don't wait until the end.
- To be a successful, a robot should be FAST at everything it does:
 - Fast to pick up the cubes
 - Fast to move around the field
 - Fast to score the cubes
- Design your robot so it is easy to drive. If your driver cannot control it, you won't be as successful.