

Ball Shifter Assembly Instructions

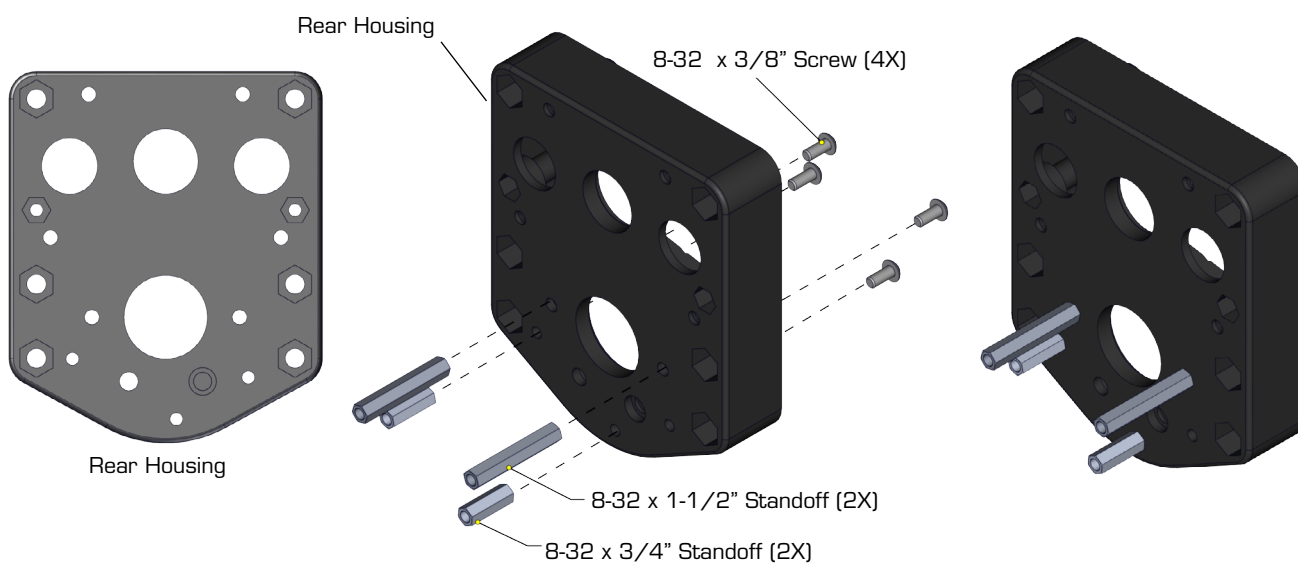

Step 1 (Grayhill Series 63R Encoder):

If using a Grayhill Series 63R encoder, use (4X) 8-32 x 3/8" screws to attach (2X) 8-32 x 1-1/2" and (2X) 8-32 x 3/4" standoffs as shown above. Use of Loctite is recommended with all screws.

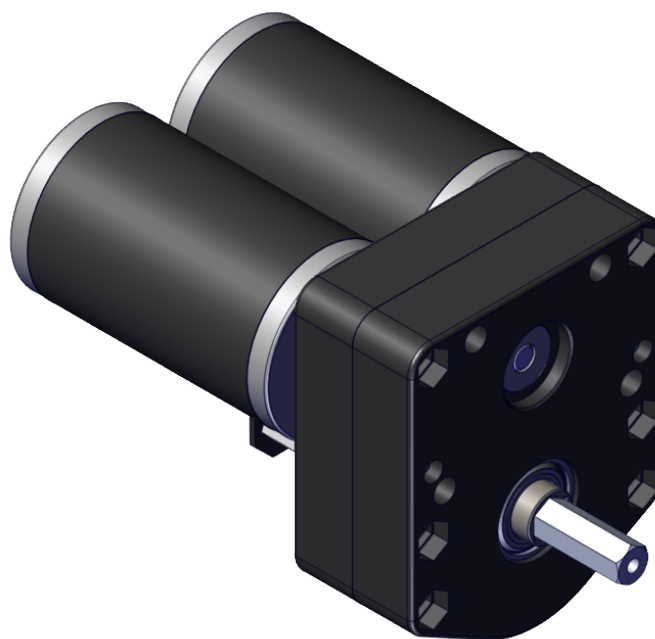
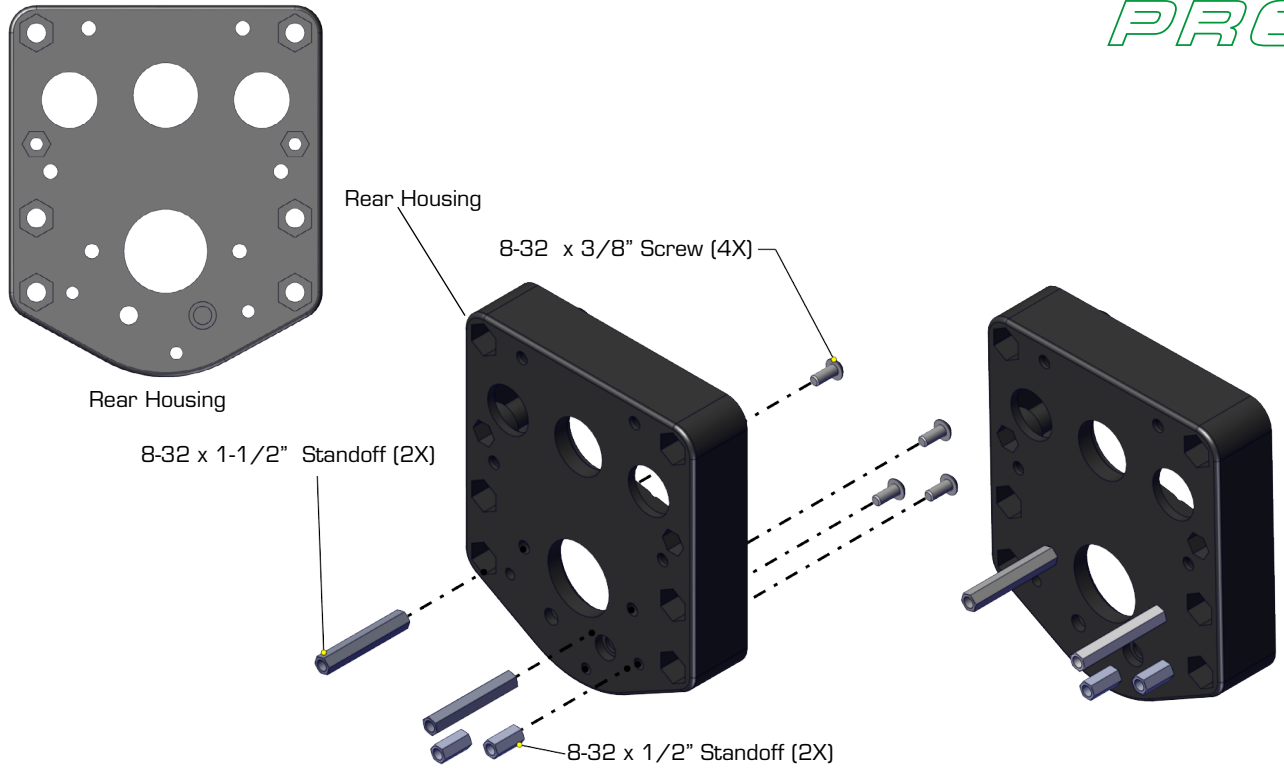

Step 1 (US Digital E4P Encoder):

If using a US Digital E4P encoder, use (4X) 8-32 x 3/8" screws to attach (2X) 8-32 x 1-1/2" and (2X) 8-32 x 1/2" standoffs as shown above. Use of Loctite is recommended with all screws.

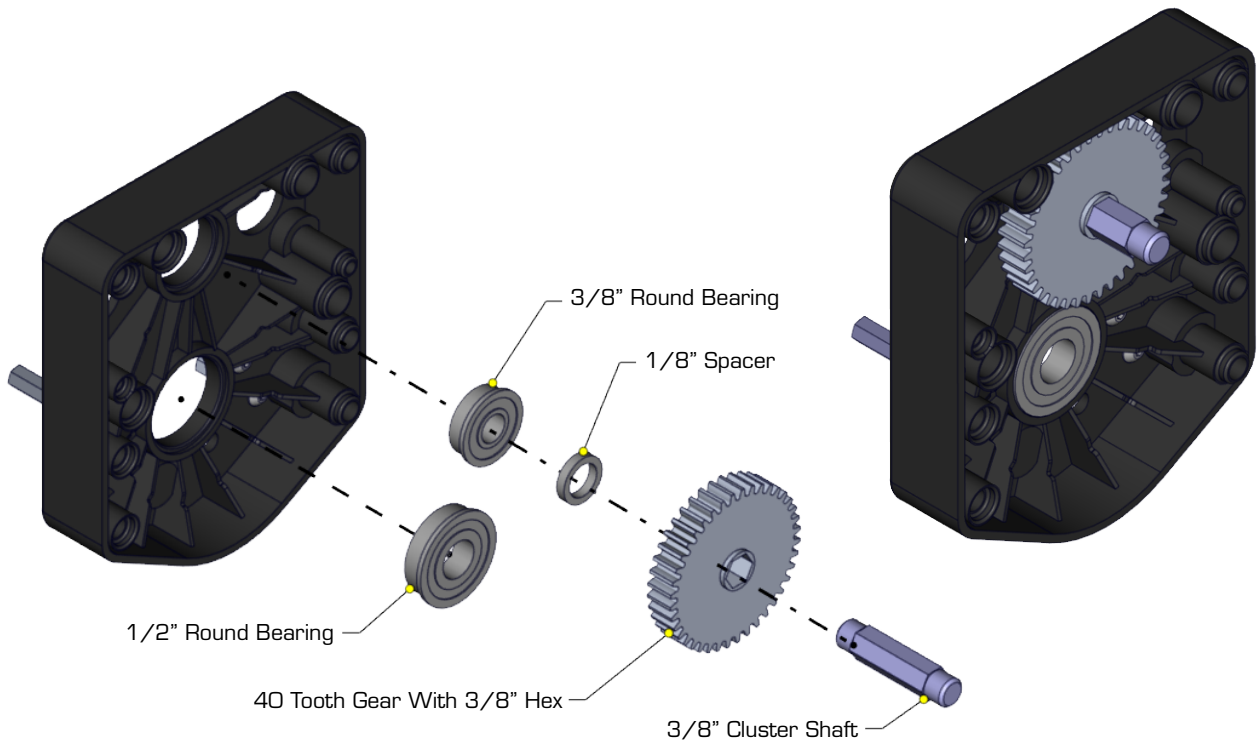

Step 2:

Insert 1/2" and 3/8" bearings, cluster shaft, 1/8" spacer, and 40 tooth gear into the back shifter housing as shown.

Note: The 1/8" spacer is the thicker of the two included spacers.

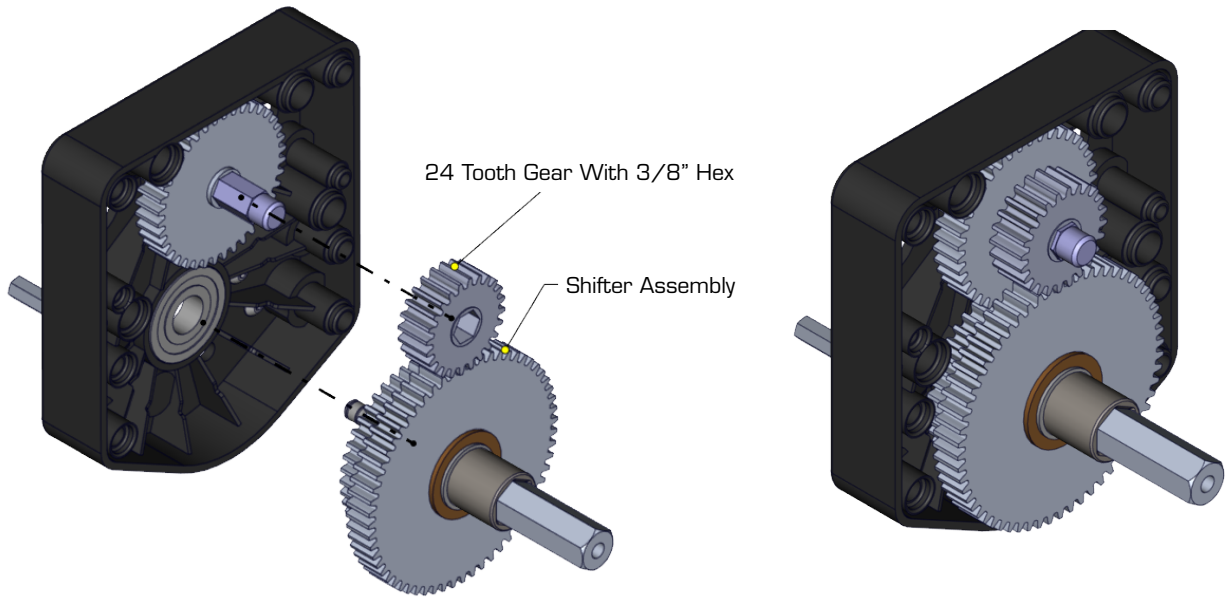

Step 3:

Install the pre-assembled shifter assembly and the 24 tooth gear as shown above.

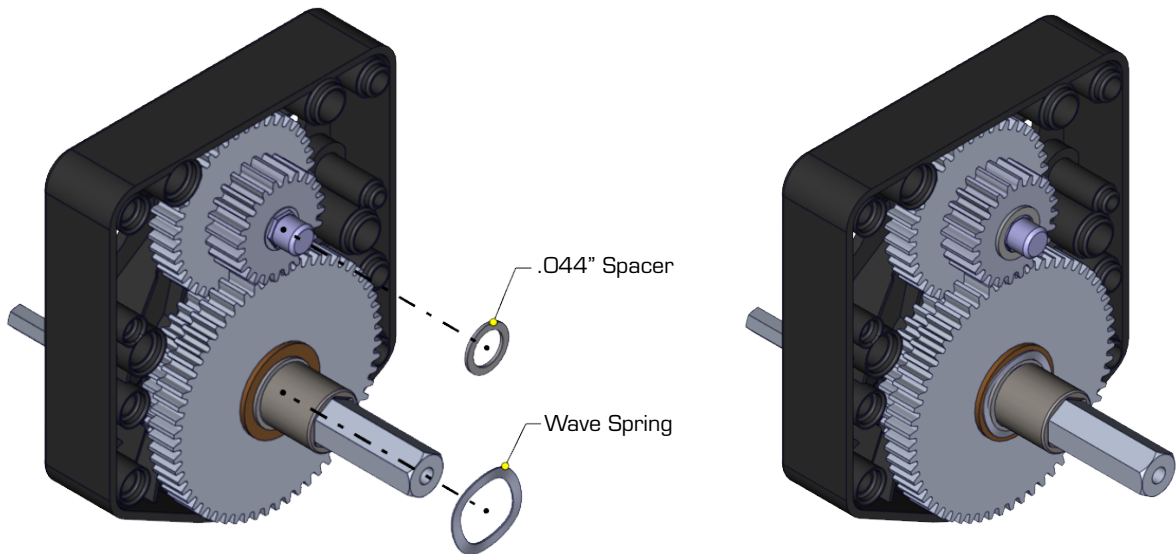

Step 4:

Install a .044" spacer as shown. Installation of the included wave spring is optional. Its use may reduce "slop" along the shifter shaft. **At this point, a liberal application of white lithium grease is required on all gears.**

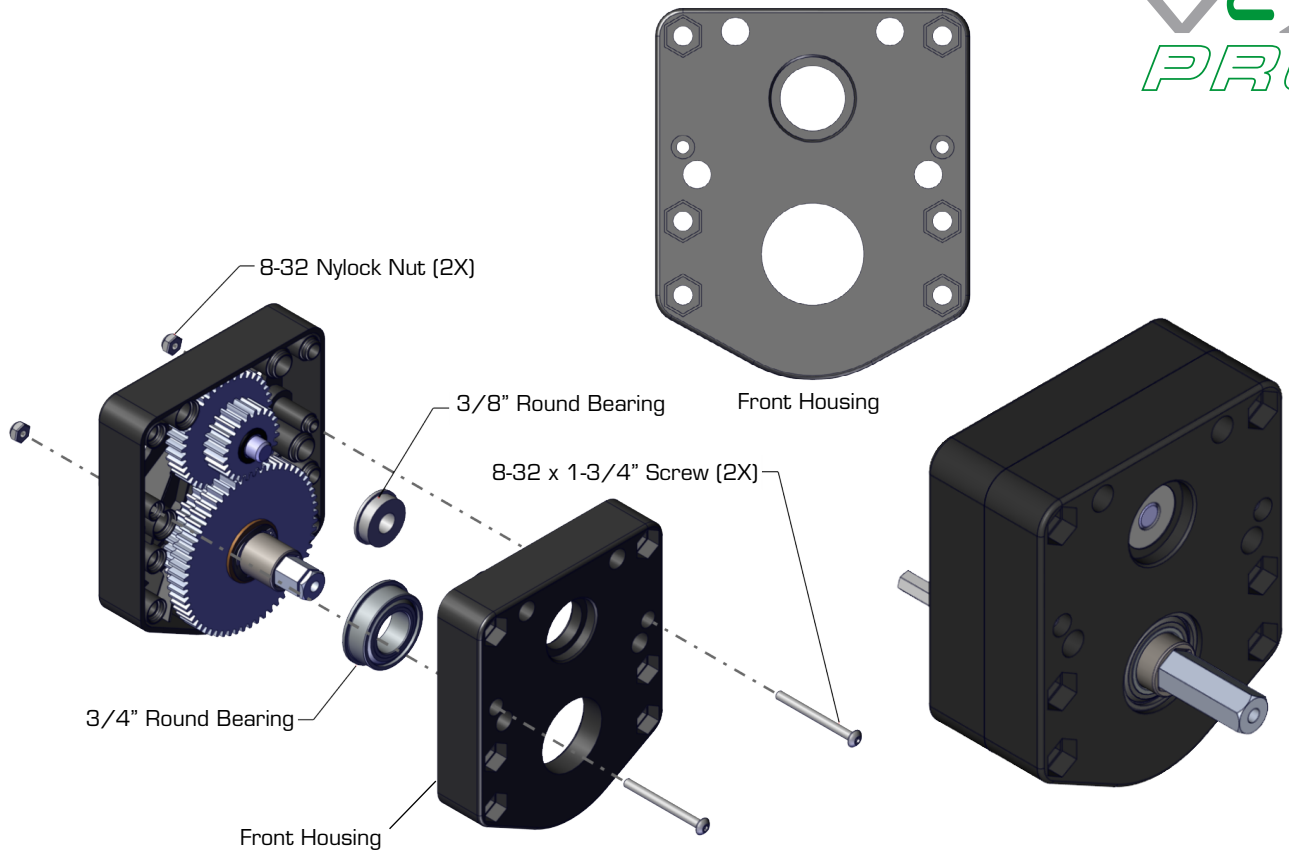

Step 5:

Insert 3/4" bearing and 3/8" bearing into front housing. Then mate the front housing with the back housing. Use (2X) 8-32 x 1-3/4" screws and (2X) 8-32 Nylock nuts as shown to hold assembly together. Use of Loctite is not recommended with Nylock nuts.

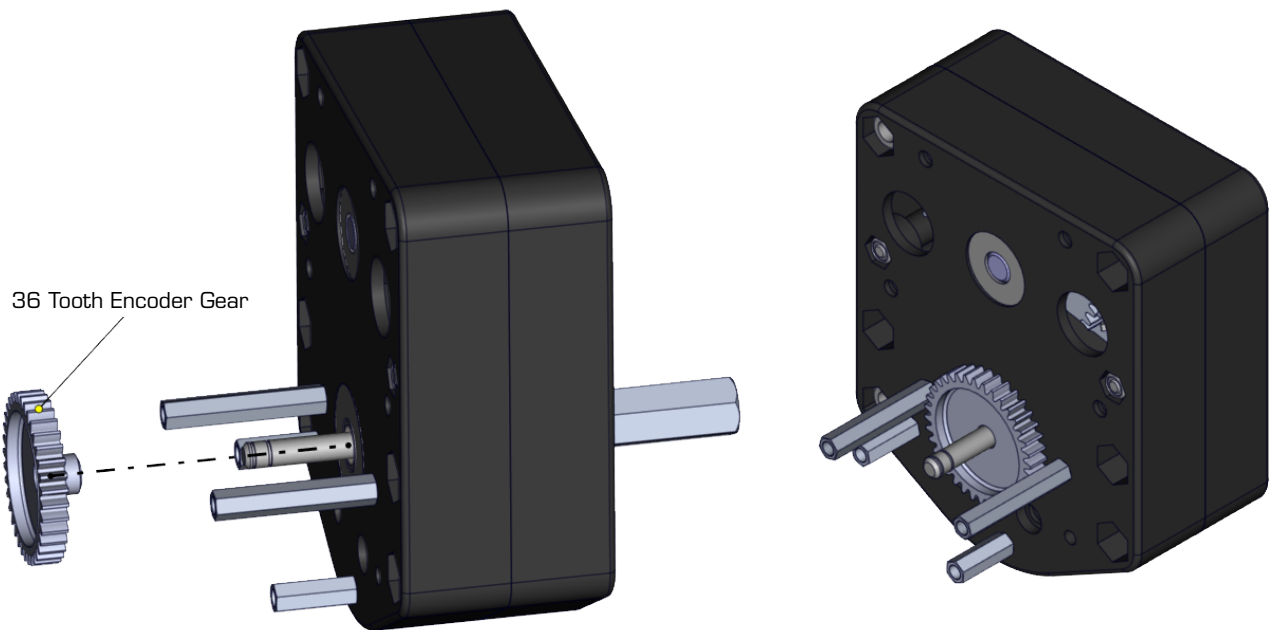

Step 6:

Insert 36 tooth encoder gear into the rear of the shifter shaft. Insertion will require a light press.

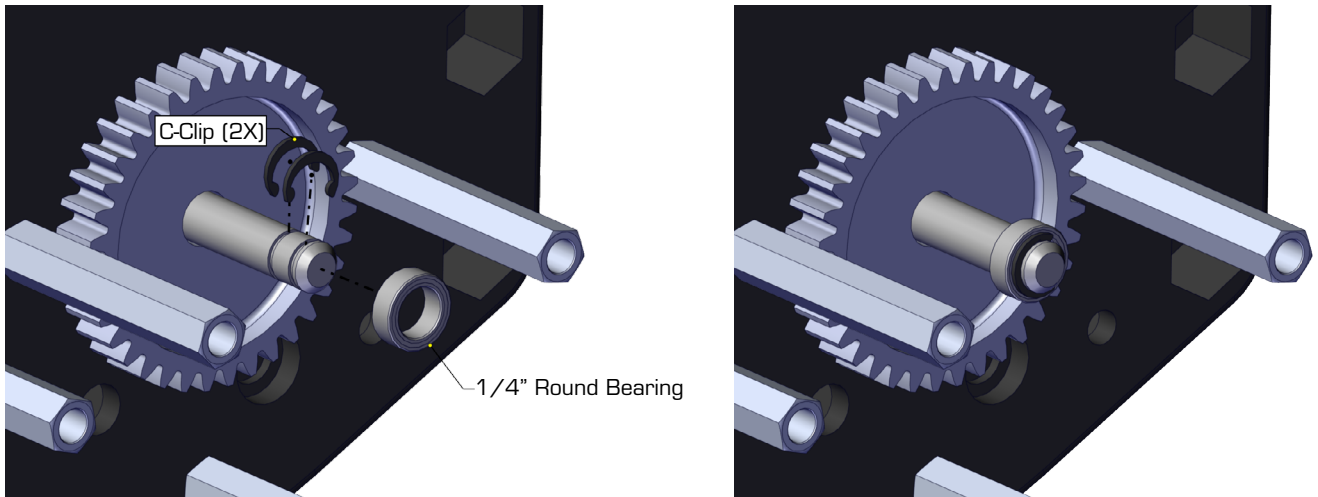

Step 7:

Install the first C-Clip into the groove closest to the encoder gear. After the first C-Clip is installed, slide the 1/4" bearing onto the shaft and install the second C-Clip to retain the bearing as shown.

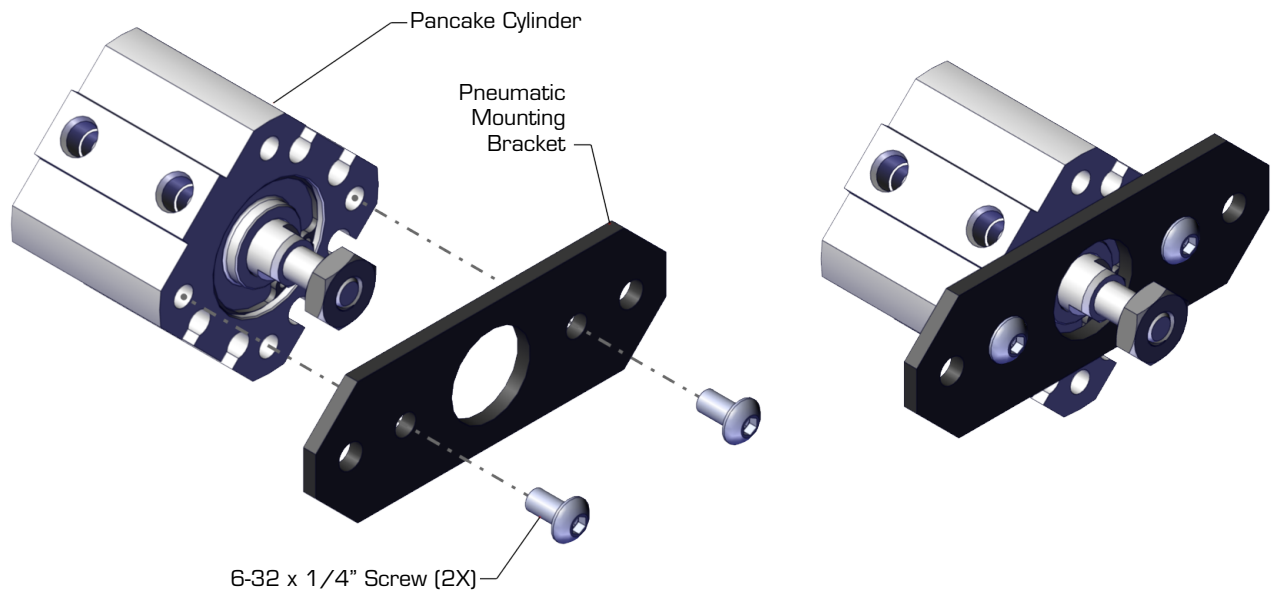

Step 8:

Install choice of pneumatic fittings. Then use (2X) 6-32 x 1/4" screws to attach the pneumatic mounting bracket to the pancake cylinder as shown.



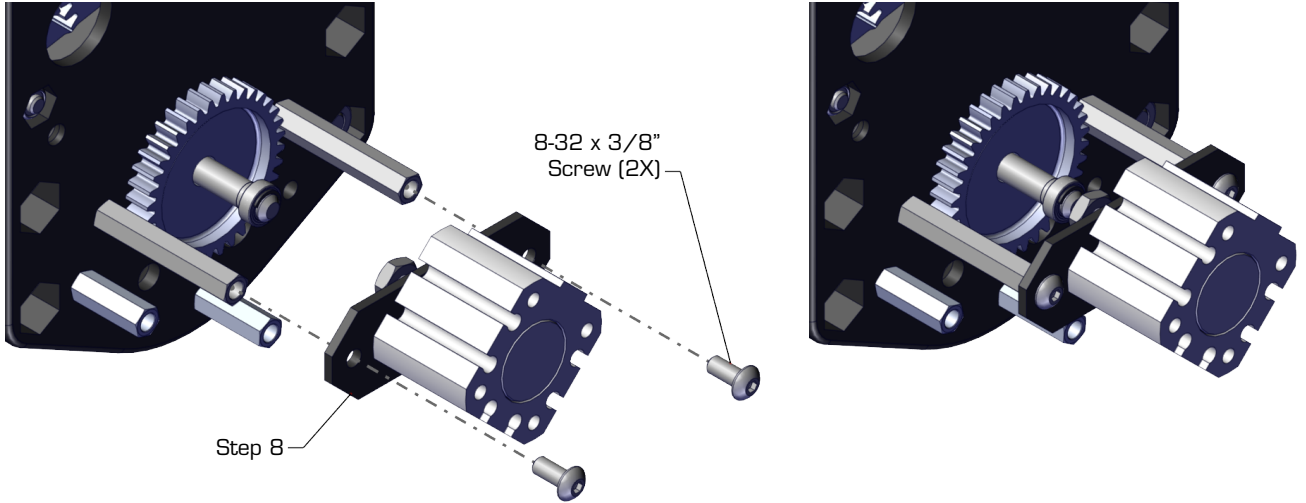

Step 9:

Use (2X) 8-32 x 3/8" screws to mount the assembly from Step 8 as shown.

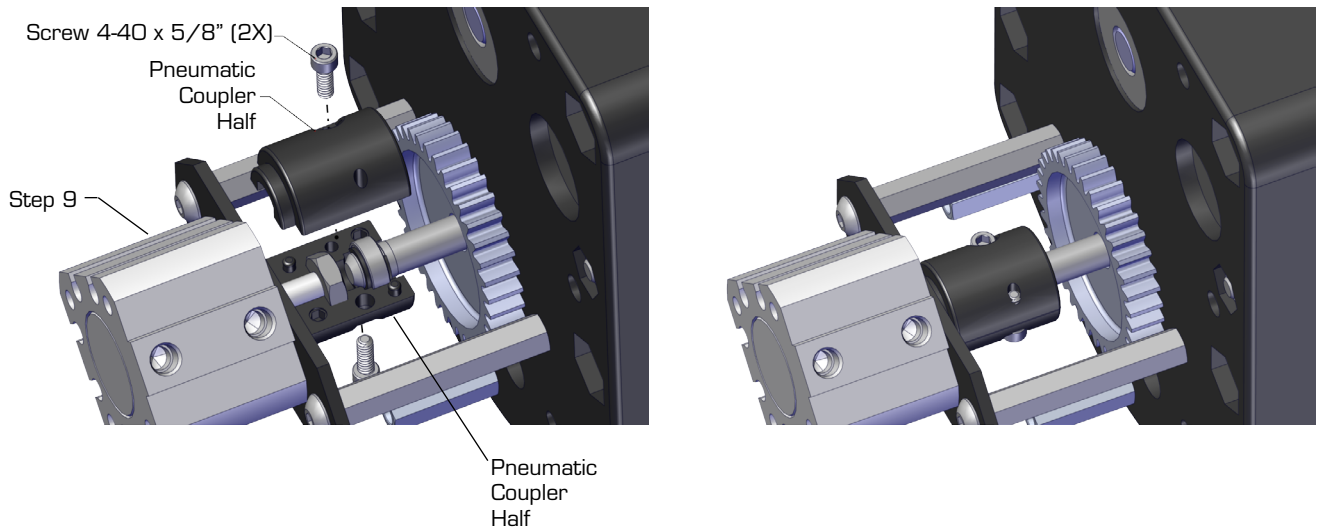

IMPORTANT: The hex nut **MUST BE FLUSH** with the end of the piston rod as illustrated.

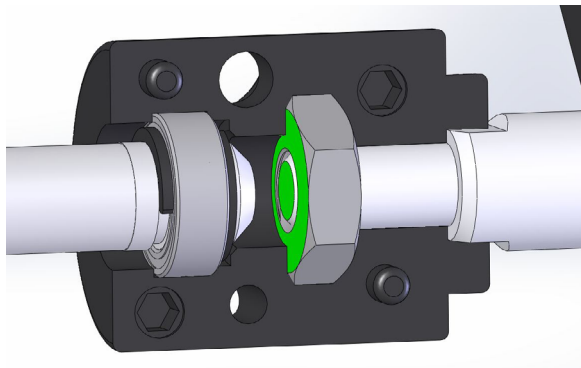

Step 10:

Use a pneumatic coupler half (both halves are identical) to capture the pancake cylinder rod and the bearing installed in Step 7 as shown. Then use (2X) 4-40 x 5/8" screws to attach the two halves as shown.

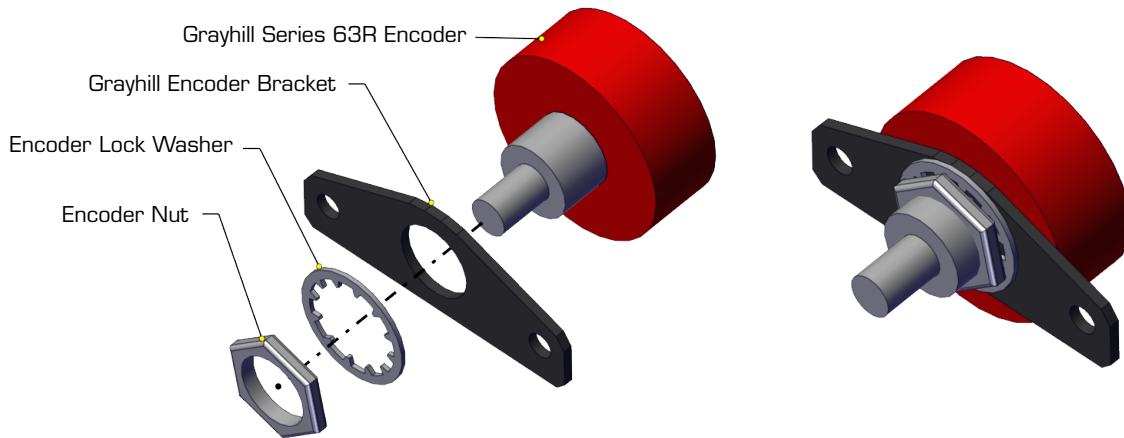

Step 11 (Grayhill Series 63R Encoder):

If using a Grayhill Series 63R encoder (not included), remove the nut and lock washer that come installed on the encoder. Re-install the nut and lock washer with the Grayhill encoder bracket as shown above.

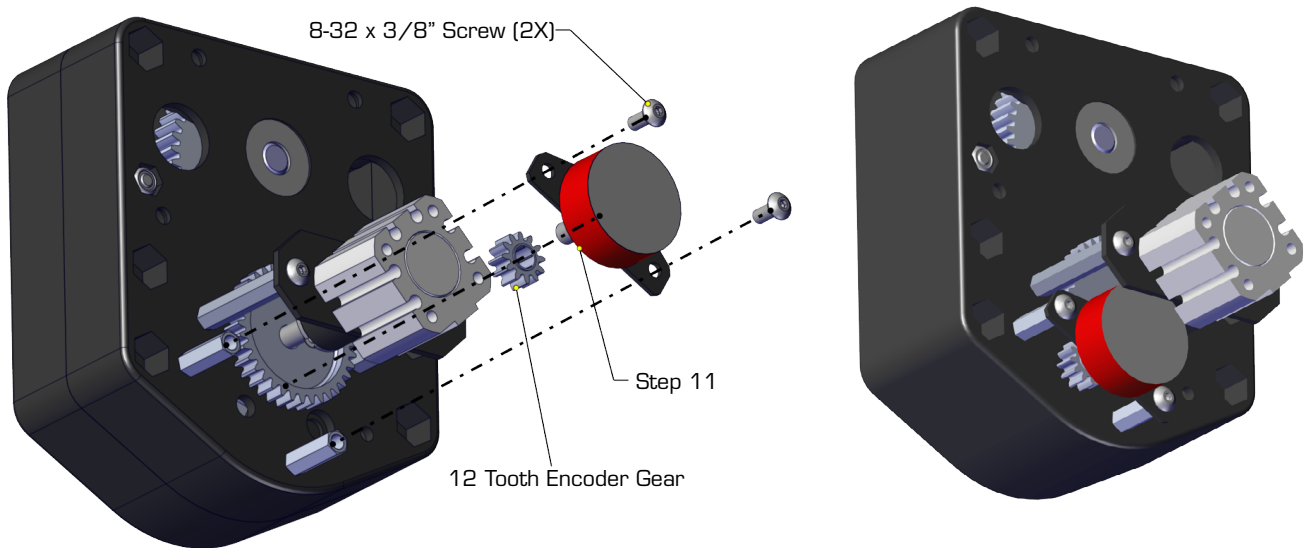

Step 12 (Grayhill Series 63R Encoder):

Press the 12 tooth encoder gear on the input shaft of the encoder, this will be a light press fit. Use (2X) 8-32 x 3/8" screws to mount the encoder assembly from Step 11 as shown. After the encoder is mounted, adjust the position of the 12 tooth gear to ensure it is not rubbing on the rear housing.

Note: The ratio between the output shaft and the encoder is 3:1. For each revolution of the output shaft, the encoder will make 3 revolutions.



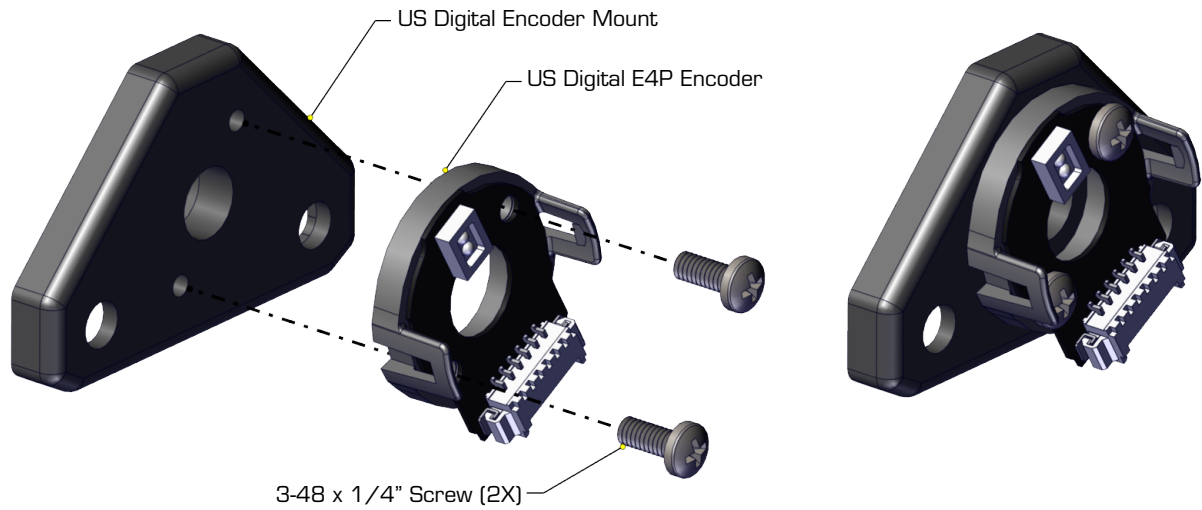

Step 11 (US Digital E4P Encoder):

If using the US Digital encoder (not included). Use the (2X) 3-48 x 1/4" screws included with the E4P Encoder to mount the encoder to the US Digital encoder mount as shown.

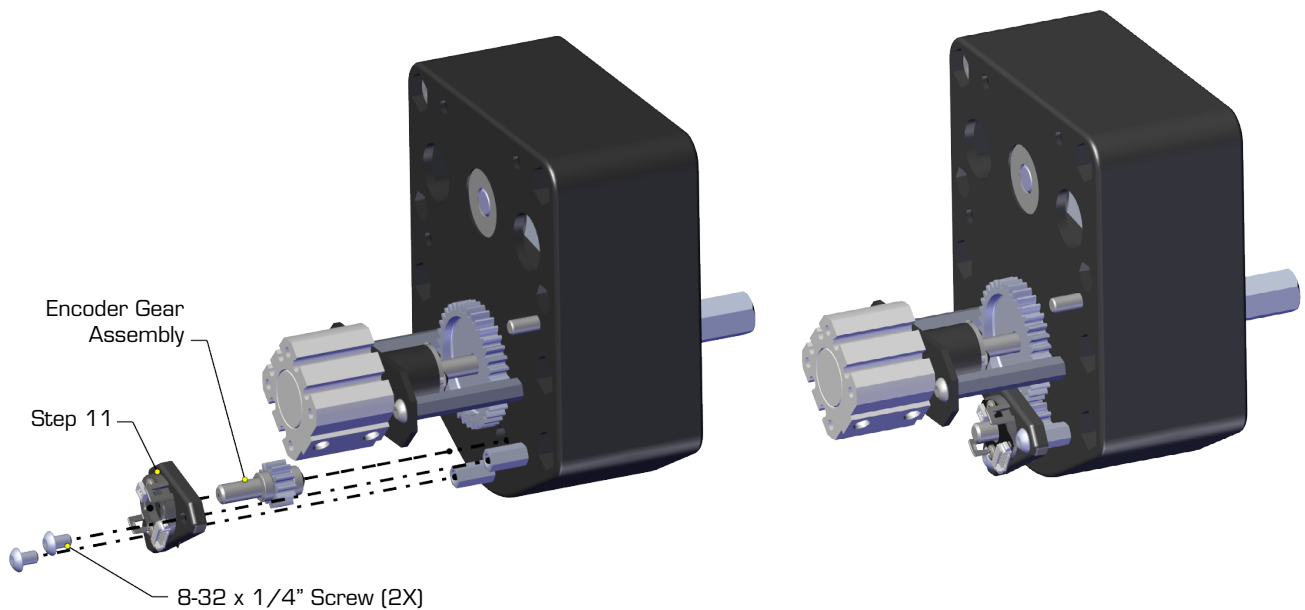

Step 12 (US Digital E4P Encoder):

Insert the encoder gear assembly into the E4P encoder then use (2X) 8-32 x 1/4" screws to mount the assembly from Step 11 as shown above. Once the encoder is mounted, follow US Digital's instructions for further encoder assembly.

Note: The ratio between the output shaft and the encoder is 3:1. For each revolution of the output shaft, the encoder will make 3 revolutions.

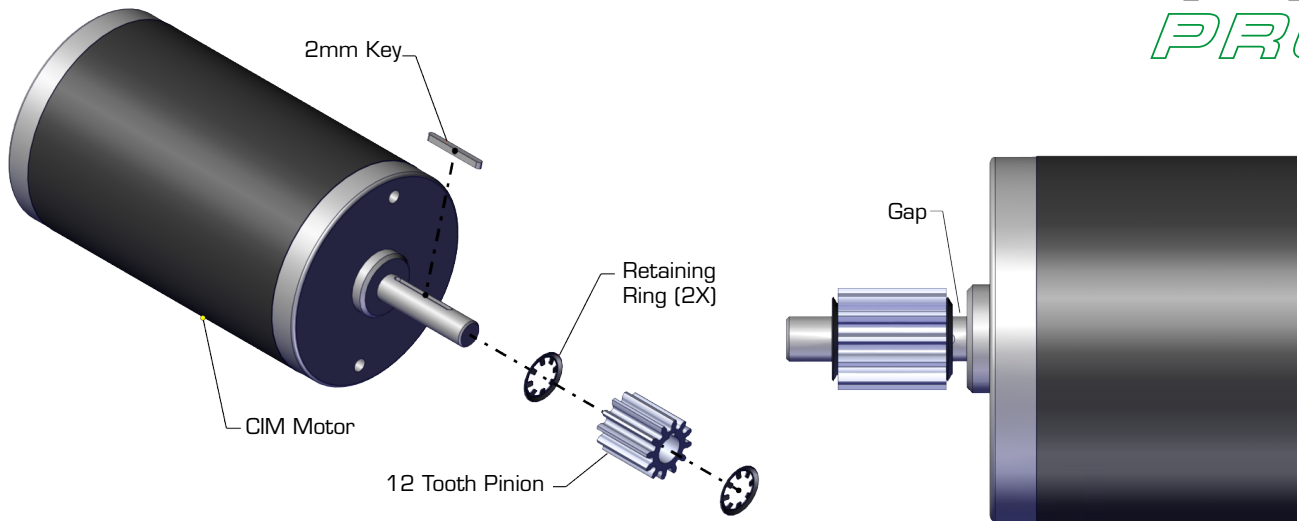

Step 13:

Use a socket to press a retaining ring onto the shaft of a CIM motor. Push the ring to the back of the keyway, but DO NOT allow it to contact the housing of the CIM motor. The “teeth” of the retaining ring should point away from the motor. Insert a 2mm key into the keyway of the CIM motor and slide the 12 tooth pinion gear on. Retain the pinion gear with a second retaining ring as shown. Repeat for a total of (2X) motor assemblies.

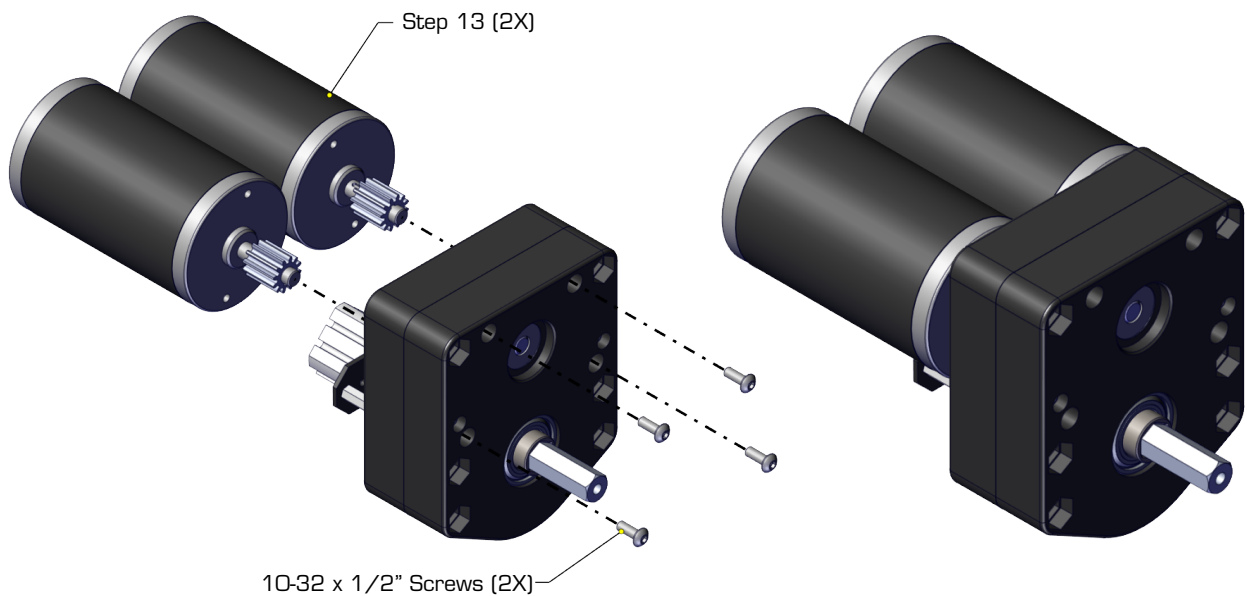

Step 14:

Use (4X) 10-32 x 1/2” screws to mount (2X) motor assemblies from Step 13.

