

VEXpro 5mm HTD Belts

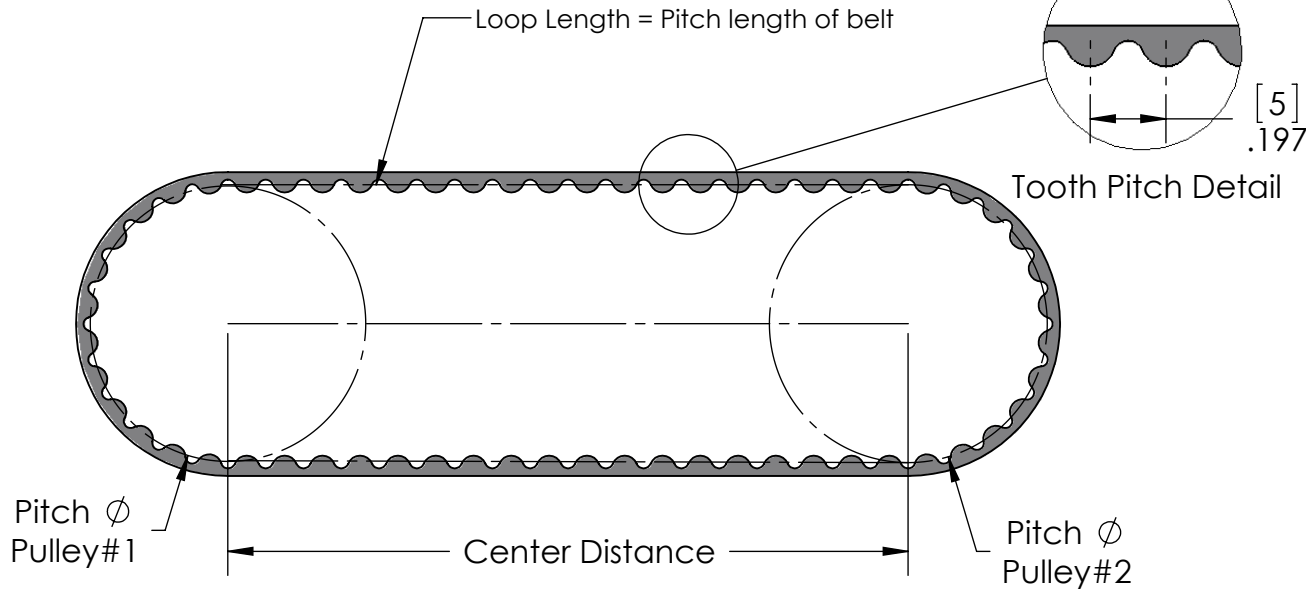

9mm Belts

15mm Belts

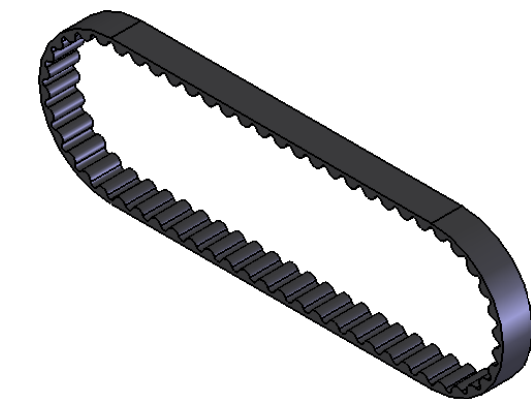
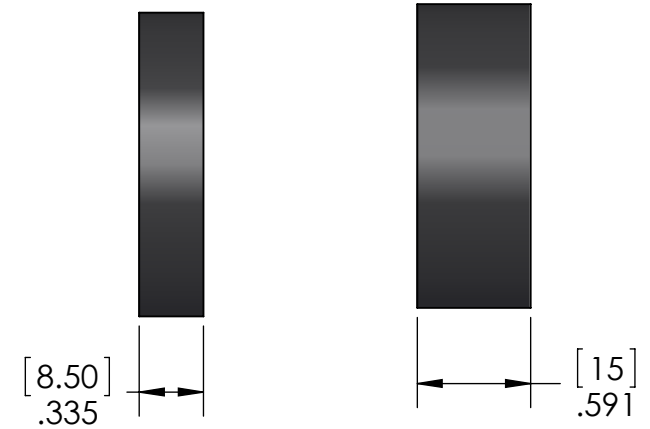

9mm Ultimate tensile strength 600lbs (single strip)

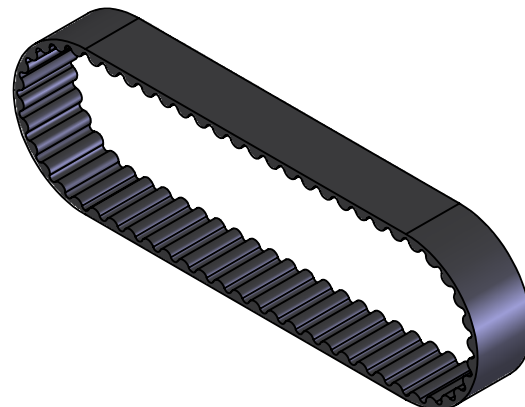

15mm Ultimate tensile strength 1100lbs (single strip)

9mm Part#	15mm Part#	# of Teeth	Pitch Length (mm)
217-3293	217-3294	60	300
217-3455	217-3472	70	350
217-3456	217-3473	80	400
217-3457	217-3474	90	450
217-3458	217-3475	100	500
217-3459	217-3476	104	520
217-3460	217-3477	110	550
217-3461	217-3478	120	600
217-3462	217-3479	130	650
2147-3463	217-3480	140	700
217-3464	217-3481	150	750
217-3465	217-3482	160	800
217-3466	217-3483	170	850
217-3467	217-3484	180	900
217-3468	217-3485	200	1000
217-3469	217-3486	225	1125
217-3470	217-3487	250	1250

For center distance design please see:
<http://www.wcproducts.net/how-to-belts/>



Description		217 Belt Details	
Dwg No		217 Belts Drawing 20150216	
Project	VEXpro	Sheet 1 of 1	
Release	2015-02-16	ALL DIMENSIONS ARE IN INCHES [MM].	

VEXPro belt lengths were chosen to be 10T increments to give ~1" (0.984") of center distance difference by moving up or down one belt size.
 Contact prosupport@VEX.com with any questions

WWW.VEXPRO.COM