

# EXP Clawbot Build Instructions



280-7735-752

# Parts List

All EXP Control System, gears, wheels, wires, and structure are not to scale  
All other parts listed are 1:1 scale.

 **46x** #8-32 Low Profile Nut

 **4x** #8 0.032" Thick Washer

 **8x** Star Drive Screw  
8-32 x 0.250" Locking

 **42x** Star Drive Screw  
8-32 x 0.375"

 **13x** Star Drive Screw 8-32 x 1.000"

 **8x** High Strength Shaft Adapter  
(1/8" Square Bore, 1/2" Long)

 **4x** High Strength Shaft Adapter  
(#8 Round Bore, 1/2" Long)

 **4x** Standoff 0.50"

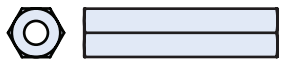
 **1x** Standoff 1.00"

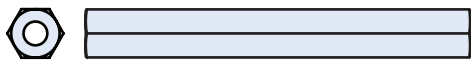
 **2x** Standoff 2.00"

 **15x** Rubber Shaft Collar

 **1x** 12T High Strength Gear

 **10x** #8 Click-On Spacer 0.125"

 **10x** #8 Click-On Spacer 0.250"

 **10x** 1 Post Standoff Retainer  
with Bearing Flat

 **8x** 1 Post Standoff Retainer

 **5x** Low Profile Bearing Flat

 **9x** Shaft Collar Retainer  
with Bearing Flat

**9x** Shaft Collar Retainer  
with Bearing Flat

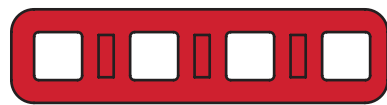
 **2x** 1x4 Plastic Linkage Beam

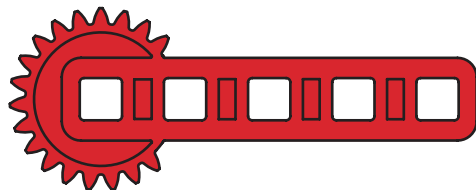
 **2x** 1x5 Crank Arm with 23T Gear

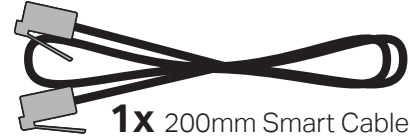
 **1x** 200mm Smart Cable

 **2x** 300mm Smart Cable

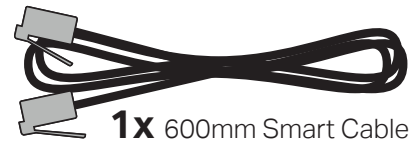
 **1x** 600mm Smart Cable

 **2x** 5" Shaft

 **2x** 2.5" Capped Shaft

 **2x** 2.5" Shaft

 **4x** 2" Shaft

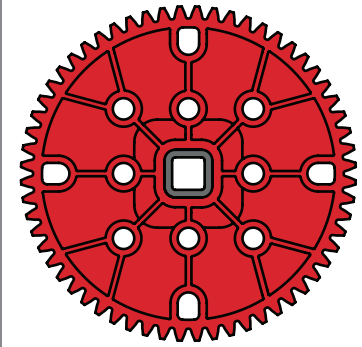

**1x** 60T High Strength Gear

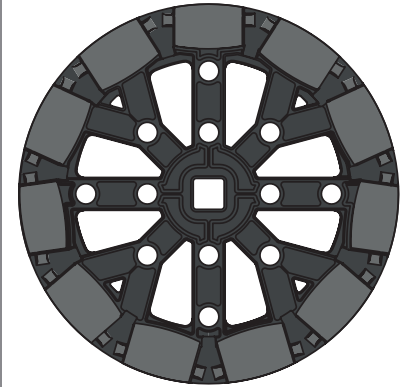

**2x** 3.25" (260 mm Travel) Anti-Static  
Omni-Directional Wheel

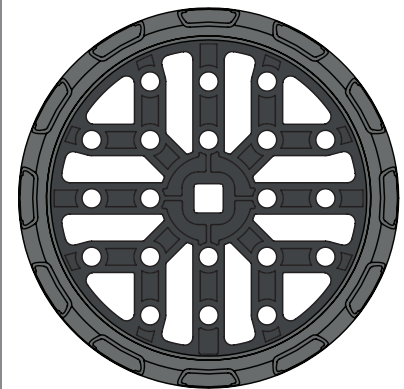

**2x** 3.25" (260mm Travel) Anti-Static  
Wheel

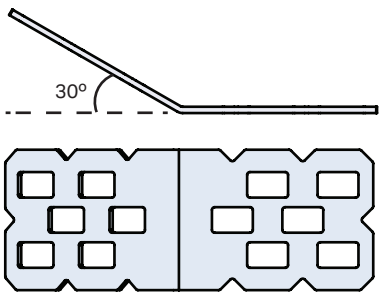

**2x** 30 Degree Bent Gusset

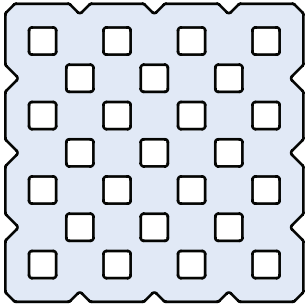

**1x** 4x4 Flat Plate

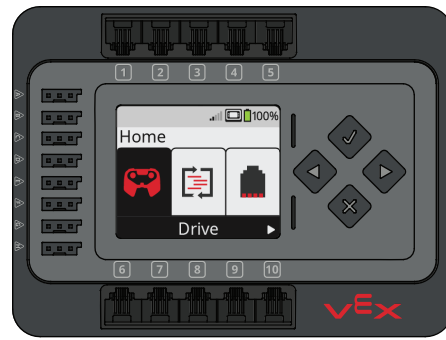

**1x** EXP Robot Brain

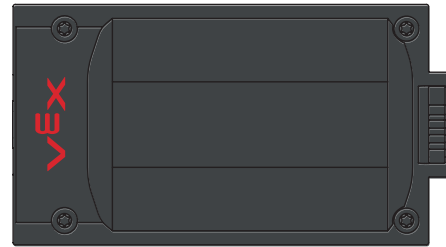

**1x** EXP Robot Battery Li-Ion 2500 mAh

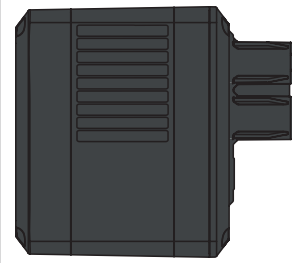

**4x** V5 Smart Motor (5.5W)

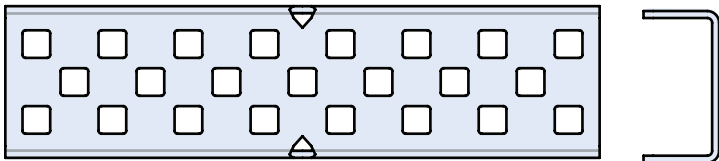

**2x** 1x2x1x8 Channel

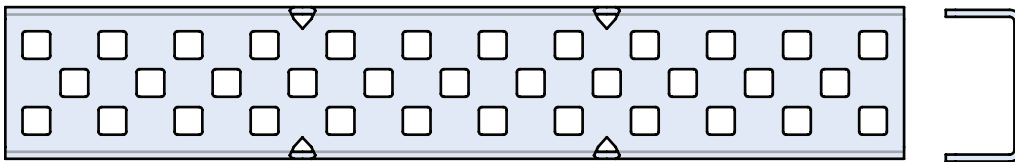

**2x** 1x2x1x12 Channel

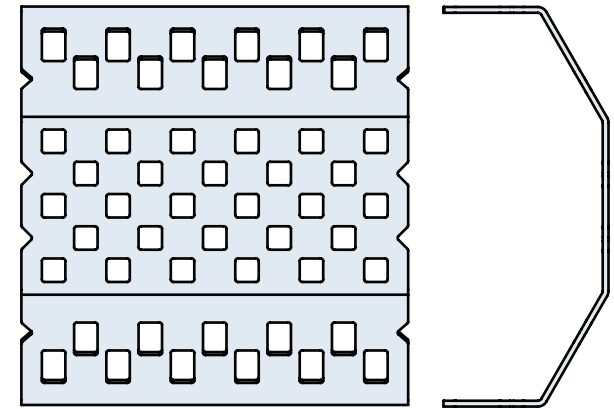

**1x** EXP Robot Brain Mounting Bracket

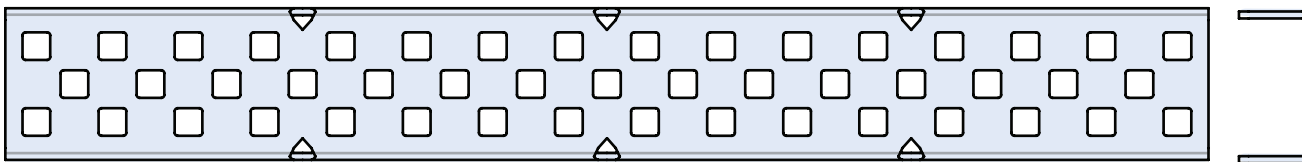

**6x** 1x2x1x16 Channel

 **2X**

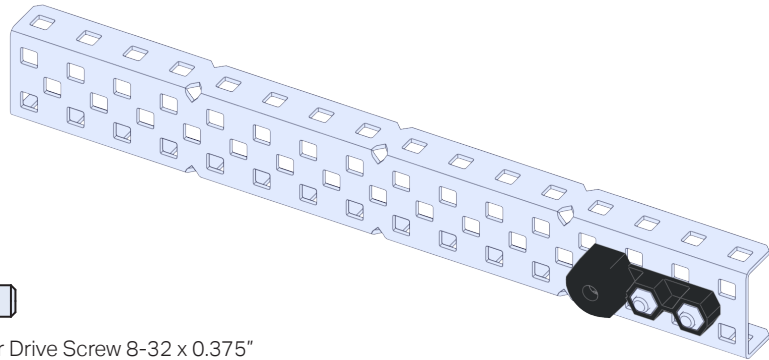
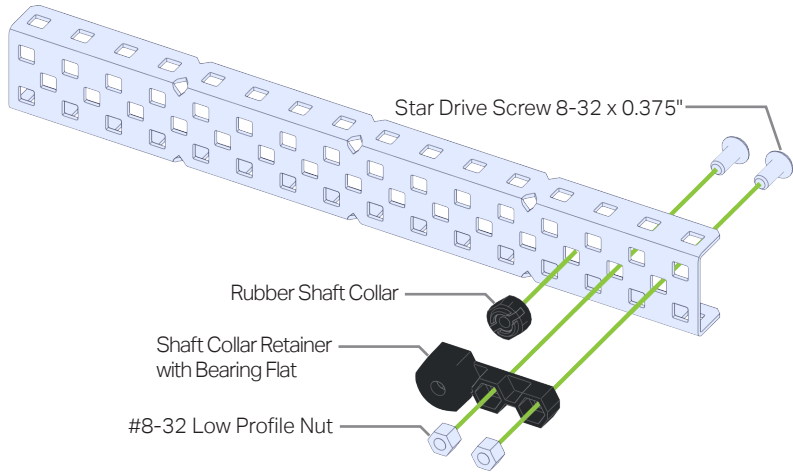

**4x** Star Drive Screw 8-32 x 0.375"



**4x** #8-32 Low Profile Nut



**2x** Rubber Shaft Collar



**2x** Shaft Collar Retainer with Bearing Flat

 **2X**

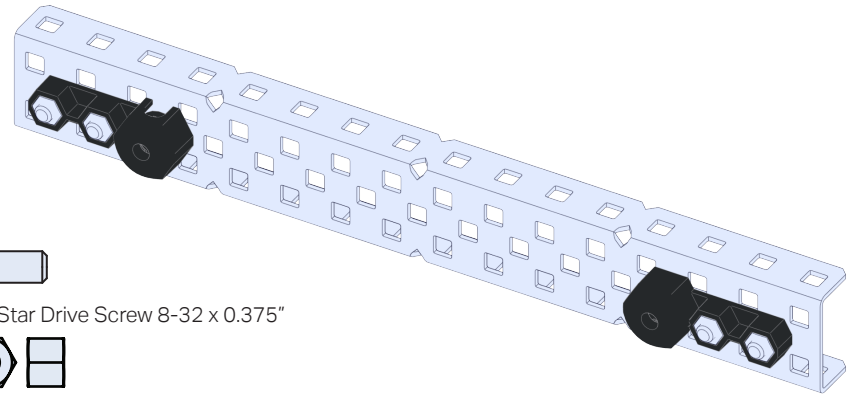
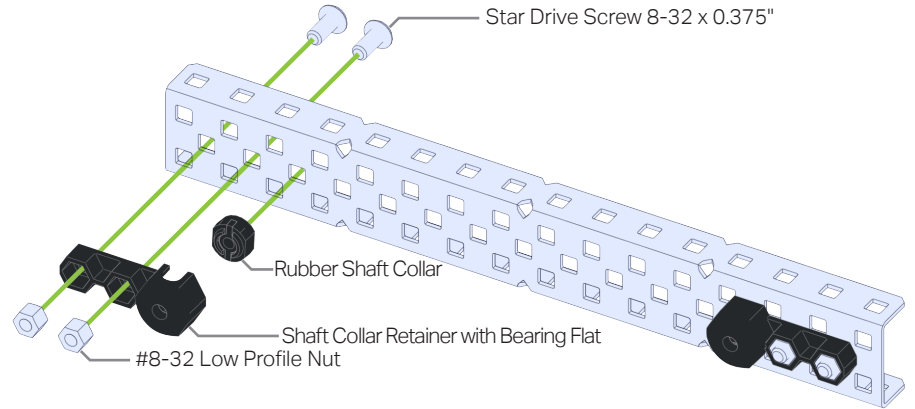

**4x** Star Drive Screw 8-32 x 0.375"



**4x** #8-32 Low Profile Nut



**2x** Rubber Shaft Collar



**2x** Shaft Collar Retainer with Bearing Flat



3

2X

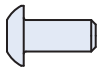
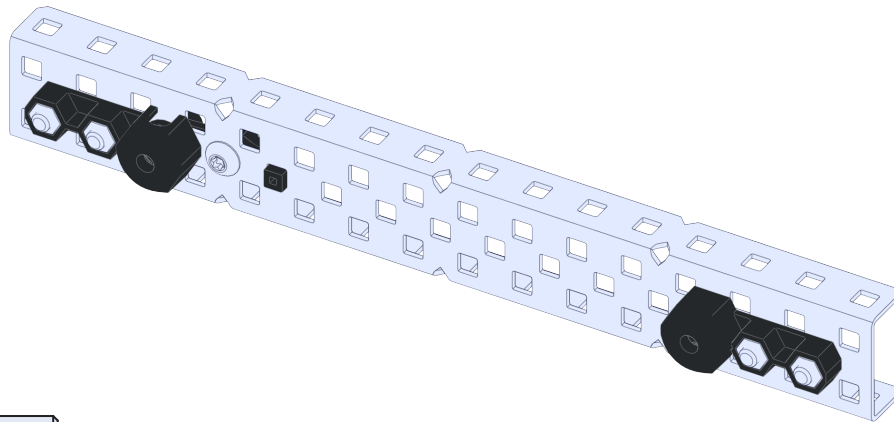
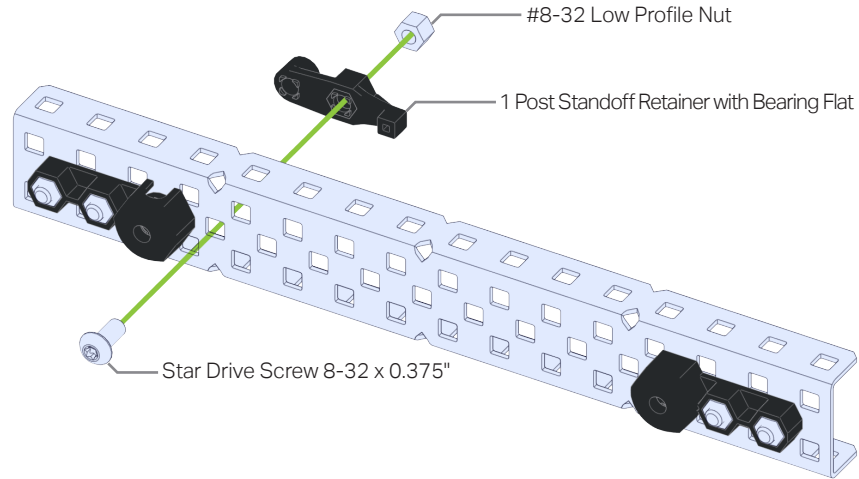

2x Star Drive Screw 8-32 x 0.375"



2x #8-32 Low Profile Nut



2x 1 Post Standoff Retainer with Bearing Flat

4

2X

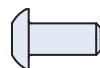
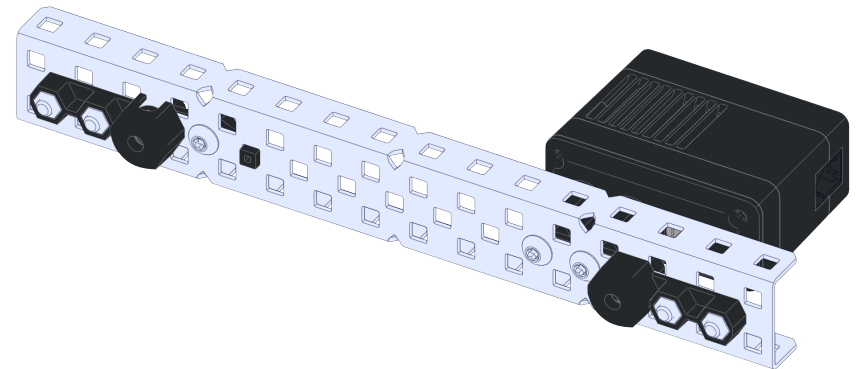
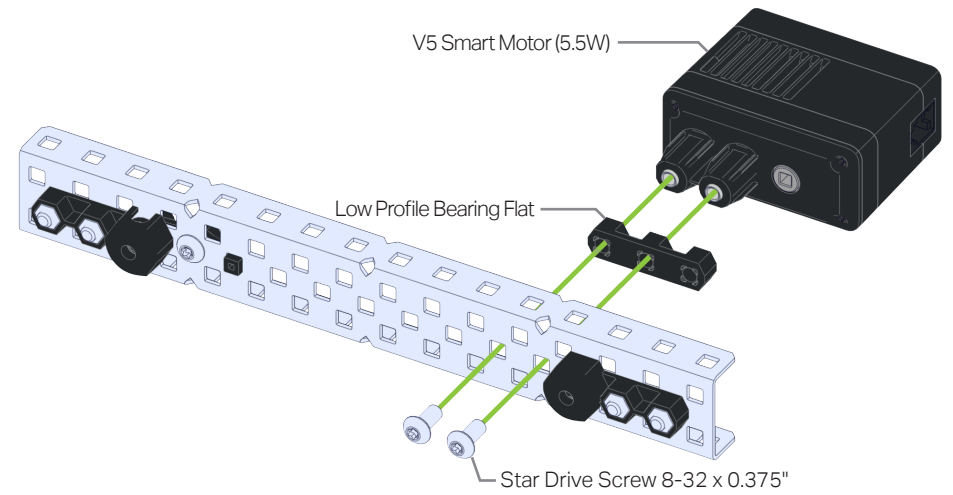

4x Star Drive Screw 8-32 x 0.375"



2x Low Profile Bearing Flat

5

2X

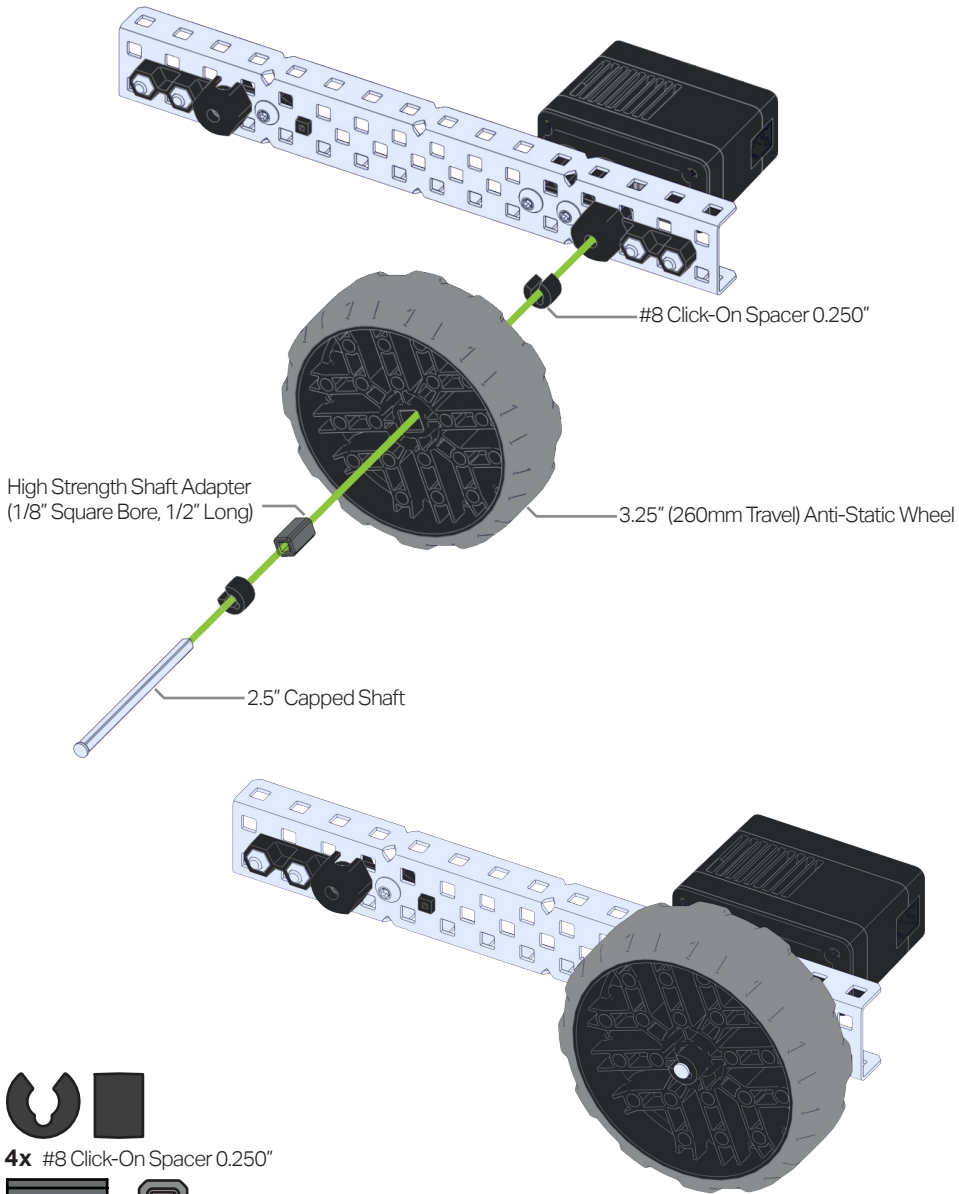

4x #8 Click-On Spacer 0.250"



2x High Strength Shaft Adapter (1/8" Square Bore, 1/2" Long)



2x 2.5" Capped Shaft

6

2X

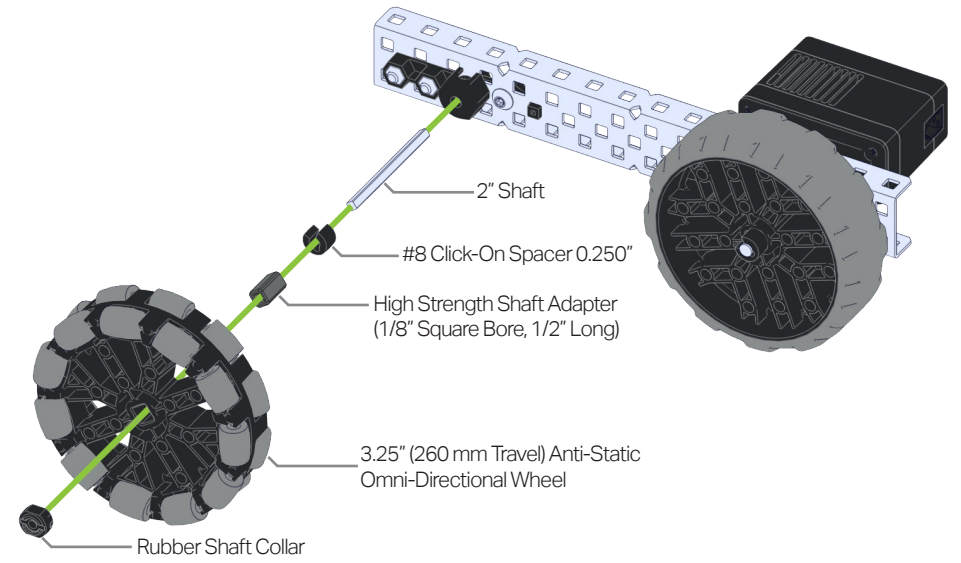

2x Rubber Shaft Collar



2x #8 Click-On Spacer 0.250"



2x High Strength Shaft Adapter (1/8" Square Bore, 1/2" Long)



2x 2" Shaft

7

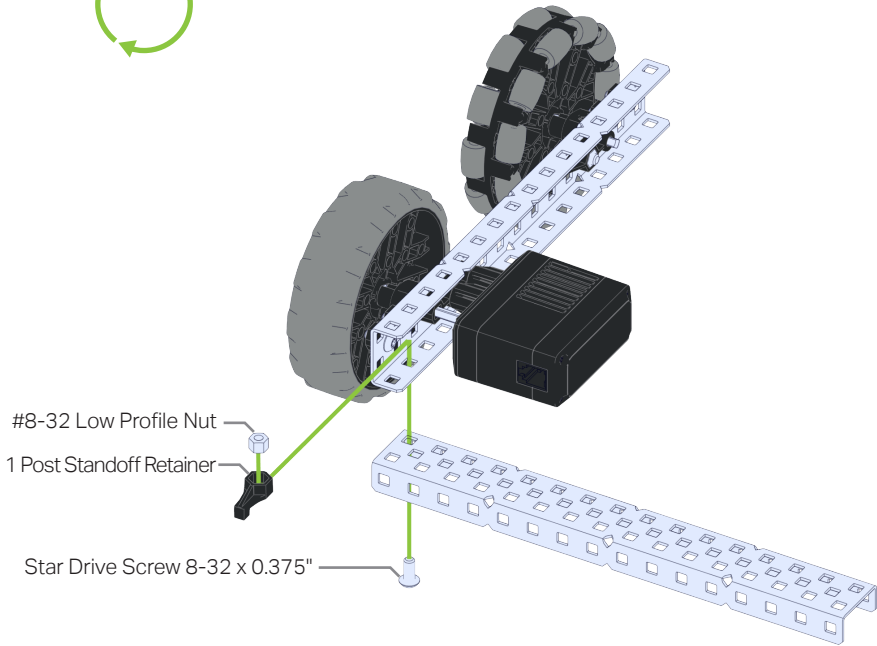

#8-32 Low Profile Nut

1 Post Standoff Retainer

Star Drive Screw 8-32 x 0.375"



1x #8-32 Low Profile Nut

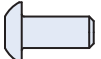

1x Star Drive Screw 8-32 x 0.375"



1x 1 Post Standoff Retainer

8

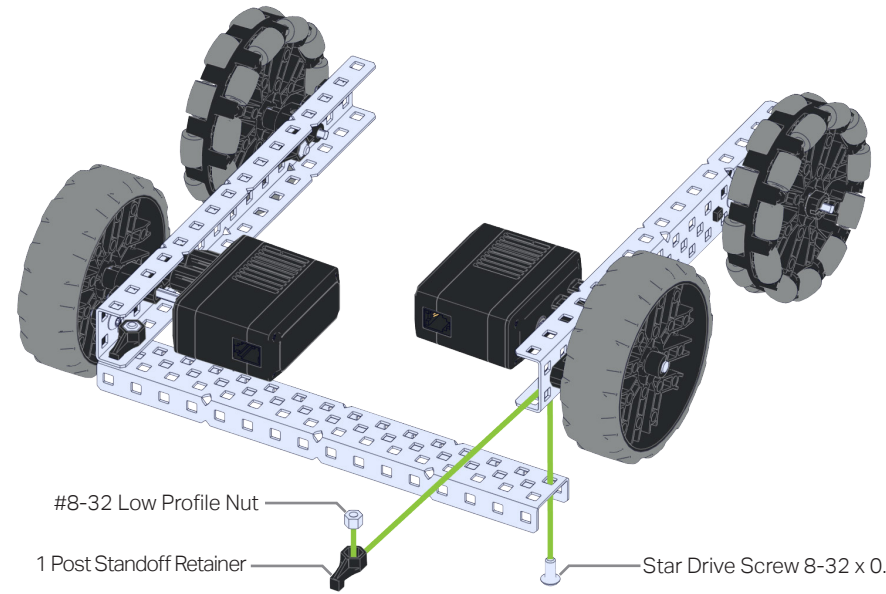

#8-32 Low Profile Nut

1 Post Standoff Retainer

Star Drive Screw 8-32 x 0.375"



1x #8-32 Low Profile Nut



1x Star Drive Screw 8-32 x 0.375"



1x 1 Post Standoff Retainer



2x #8-32 Low Profile Nut



2x Star Drive Screw 8-32 x 0.375"



2x 1 Post Standoff Retainer

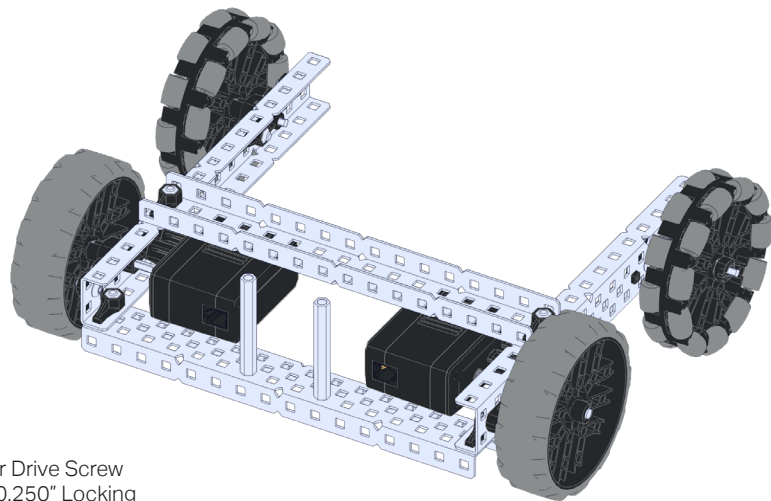
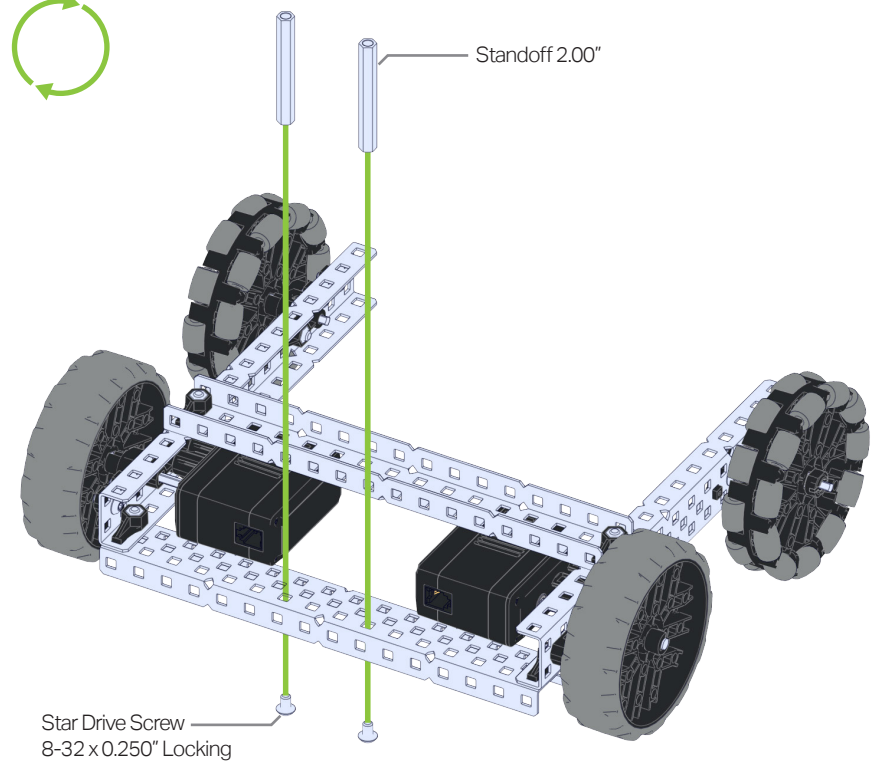
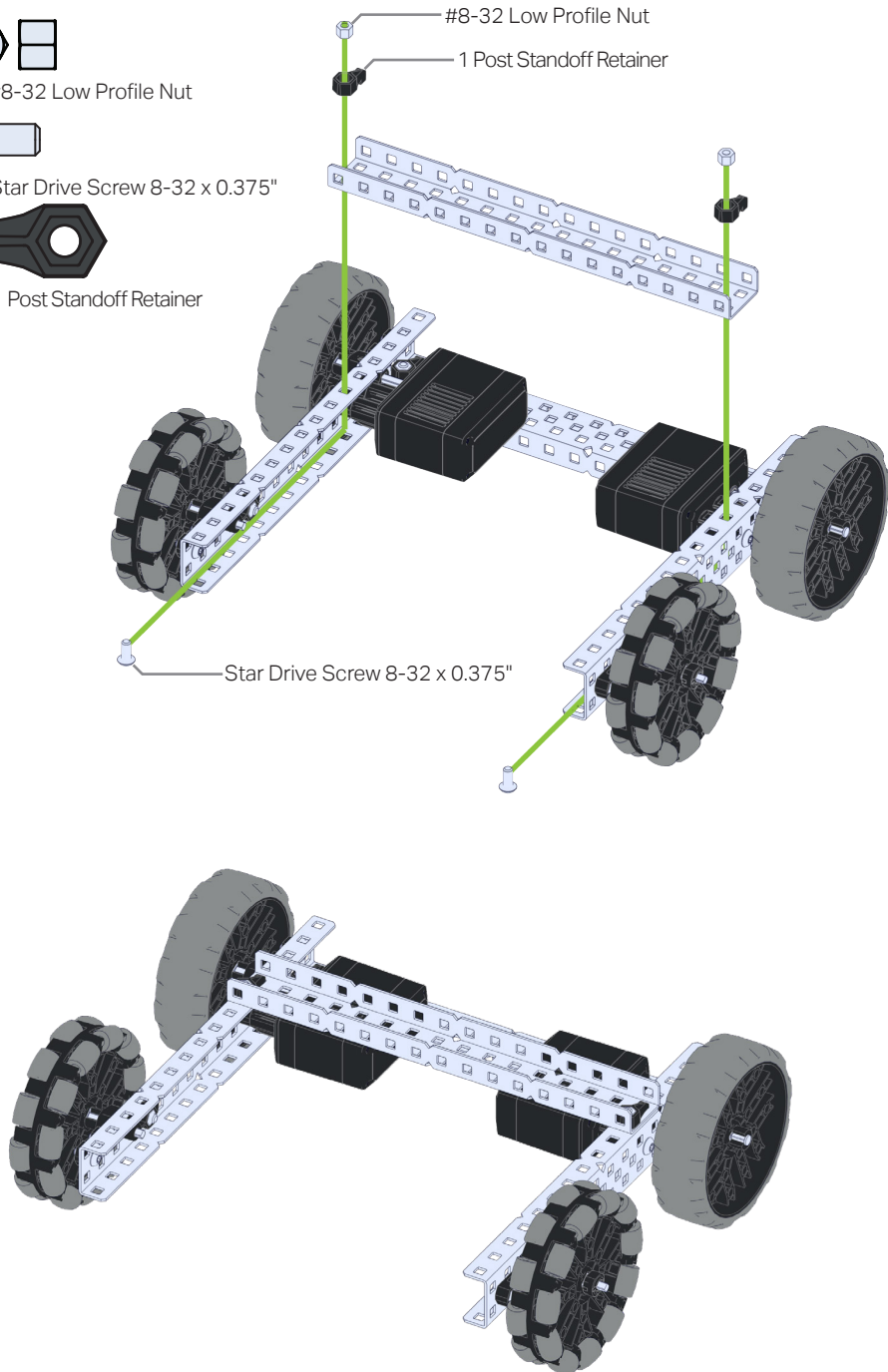

2x Star Drive Screw 8-32 x 0.250" Locking



2x Standoff 2.00"





**2x** Star Drive Screw  
8-32 x 0.250" Locking

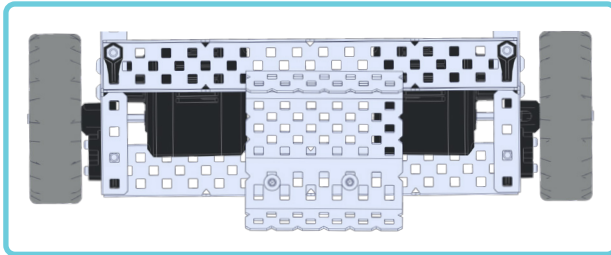
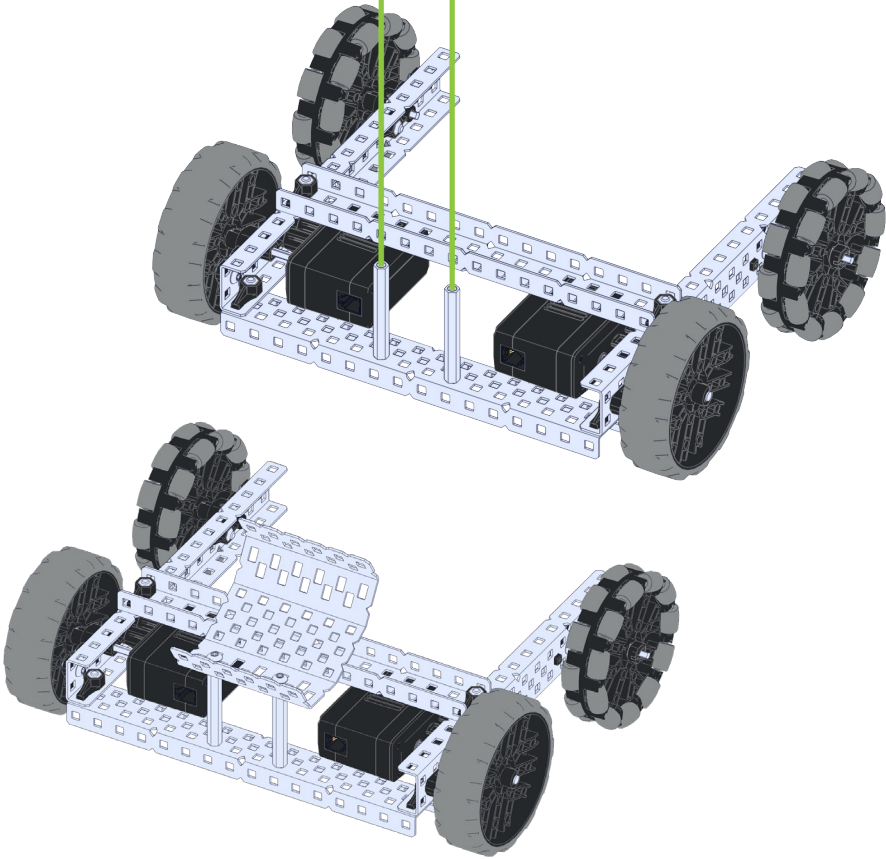
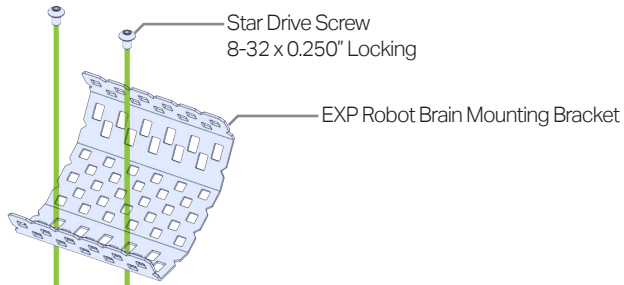

**4x** #8-32 Low Profile Nut

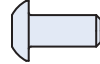

**4x** Star Drive Screw  
8-32 x 0.375"

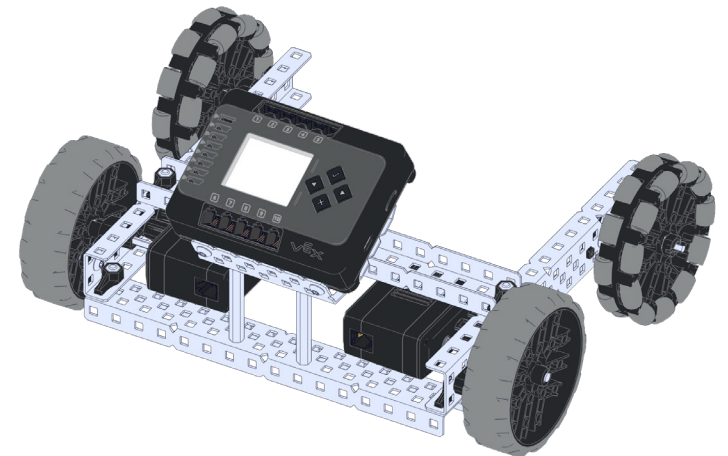
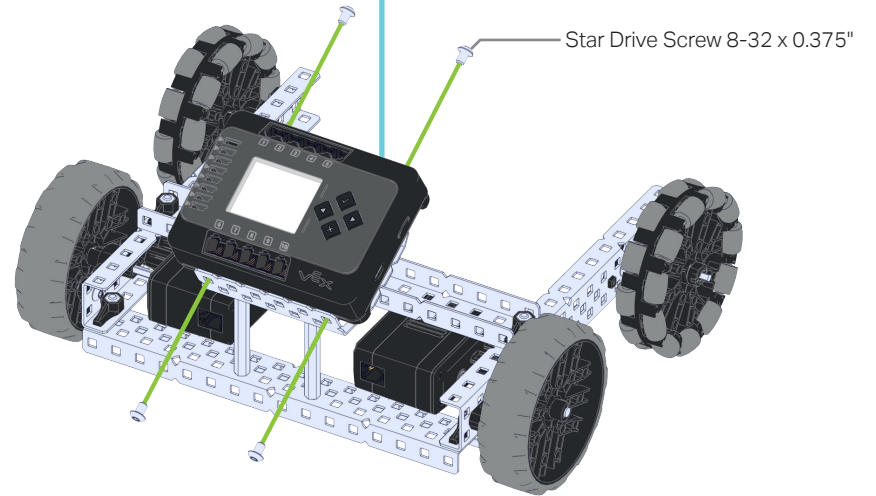
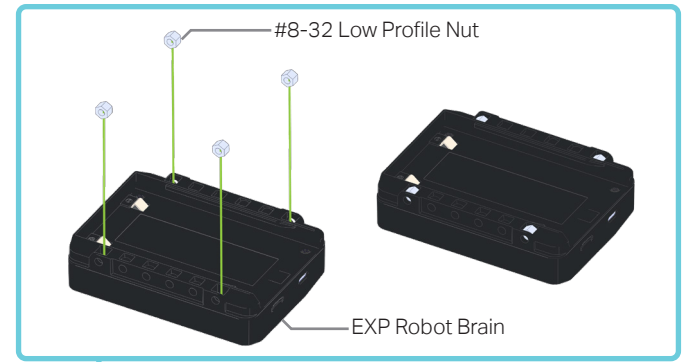

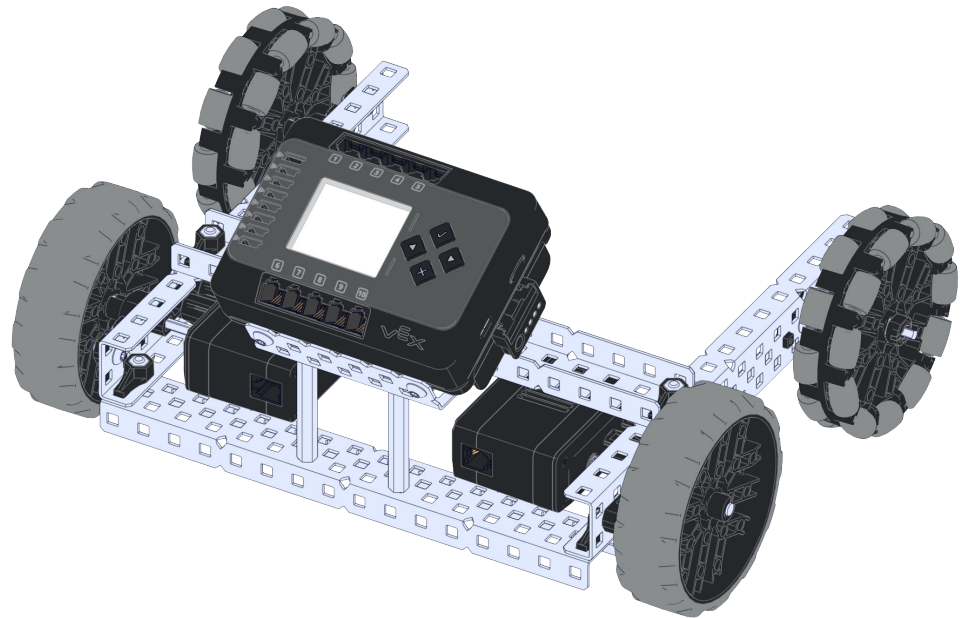
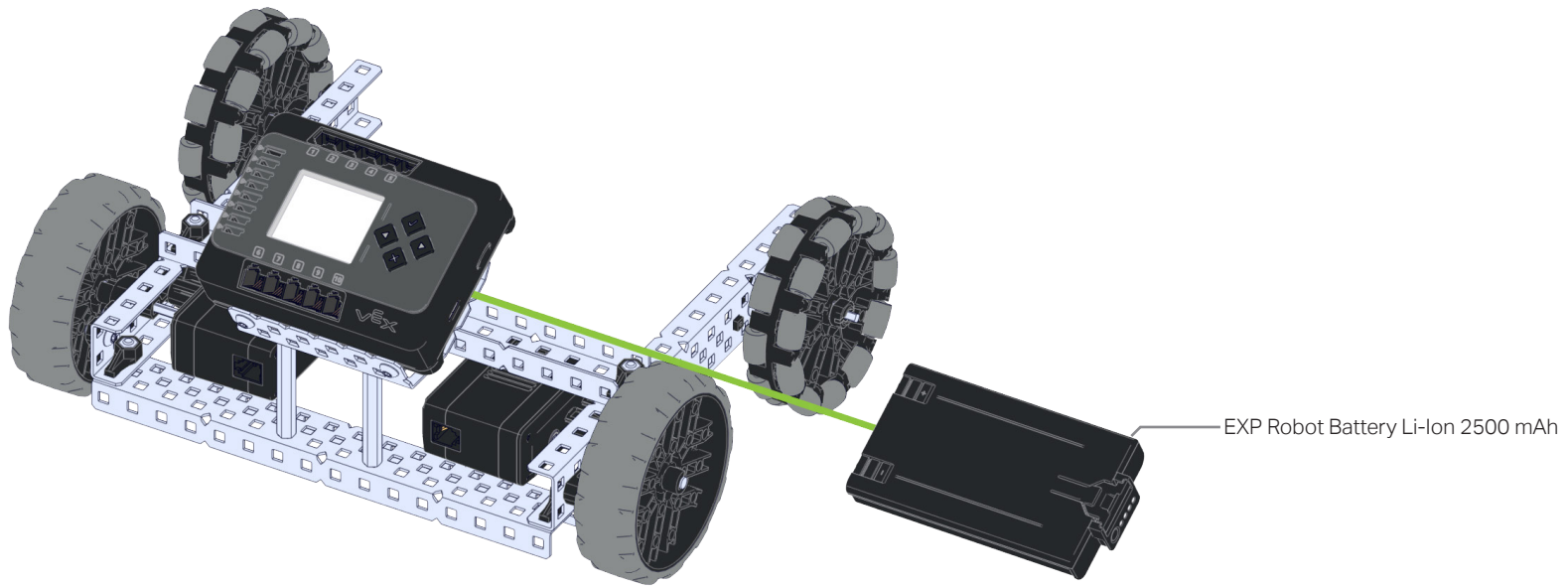

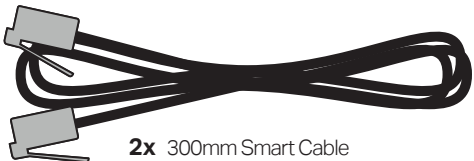
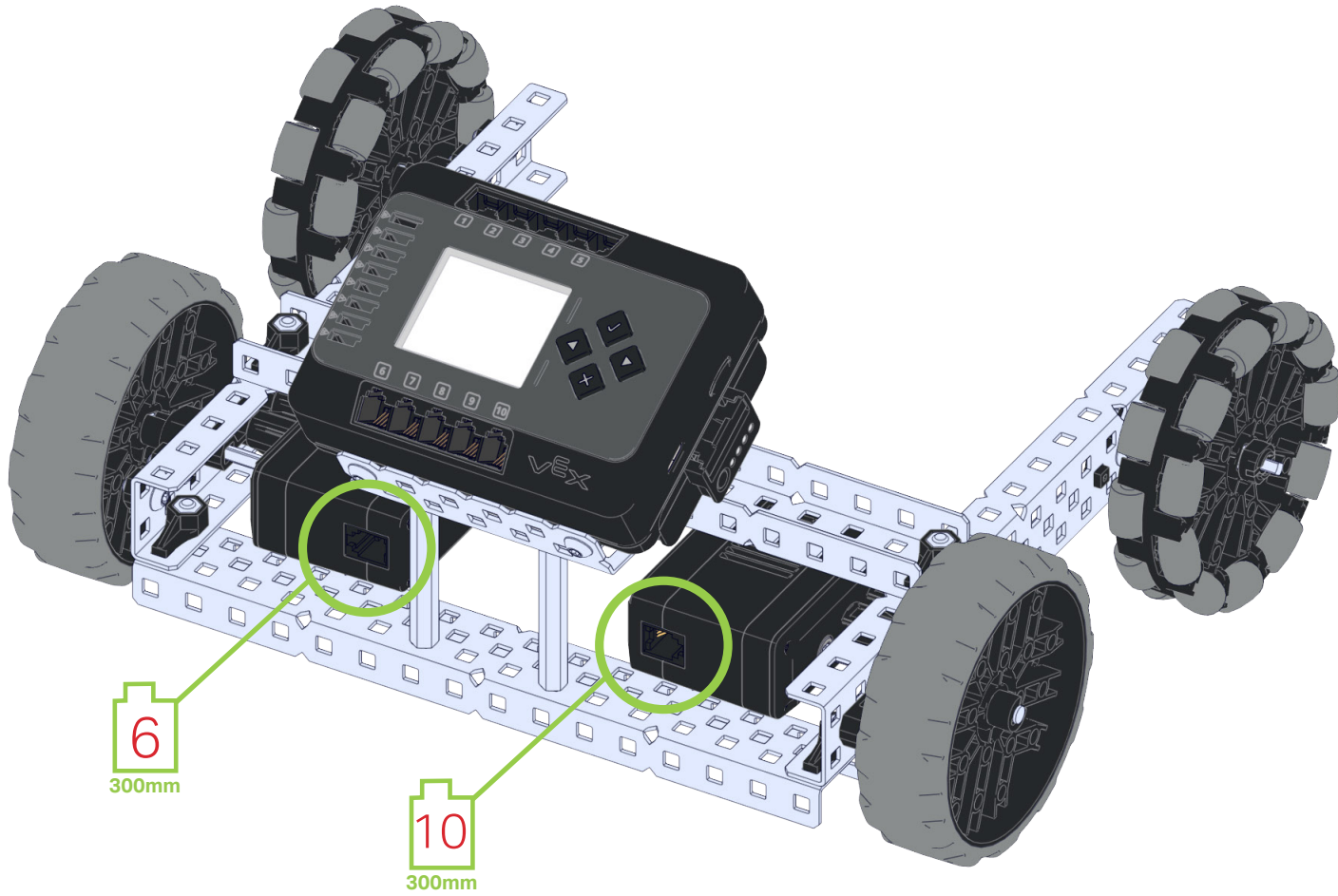

2x 300mm Smart Cable

15

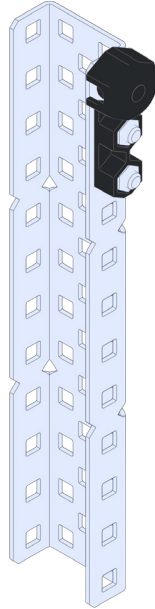
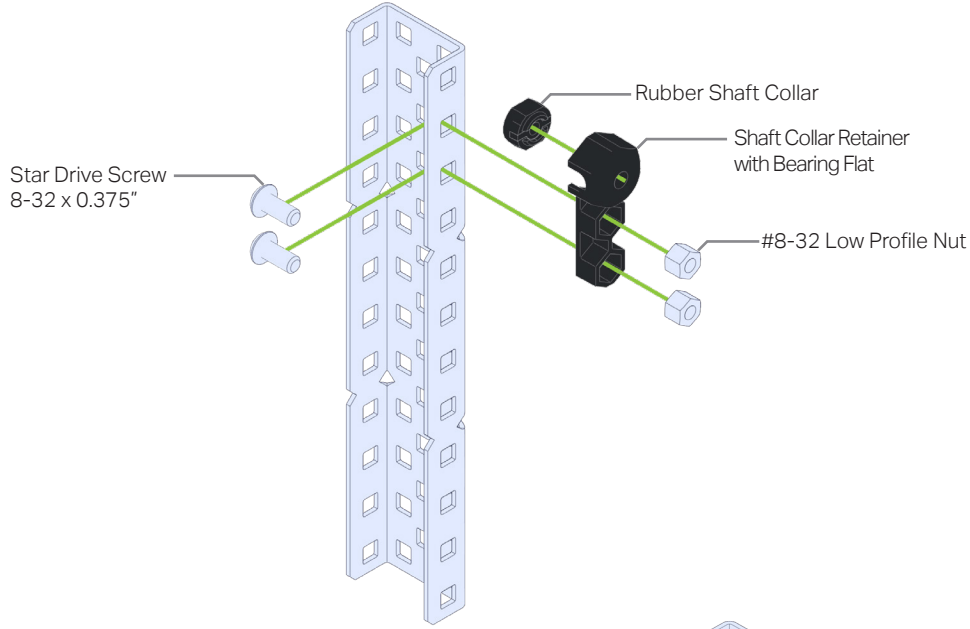

2x Star Drive Screw 8-32 x 0.375"



2x #8-32 Low Profile Nut



1x Rubber Shaft Collar



1x Shaft Collar Retainer with Bearing Flat

16

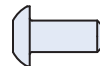
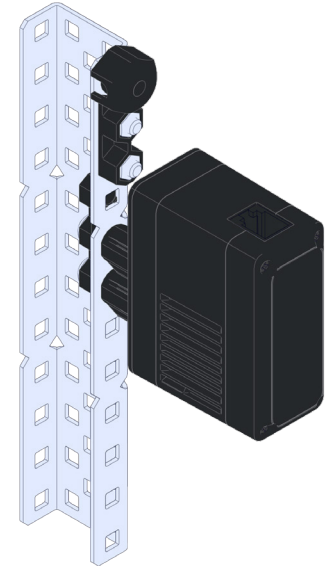
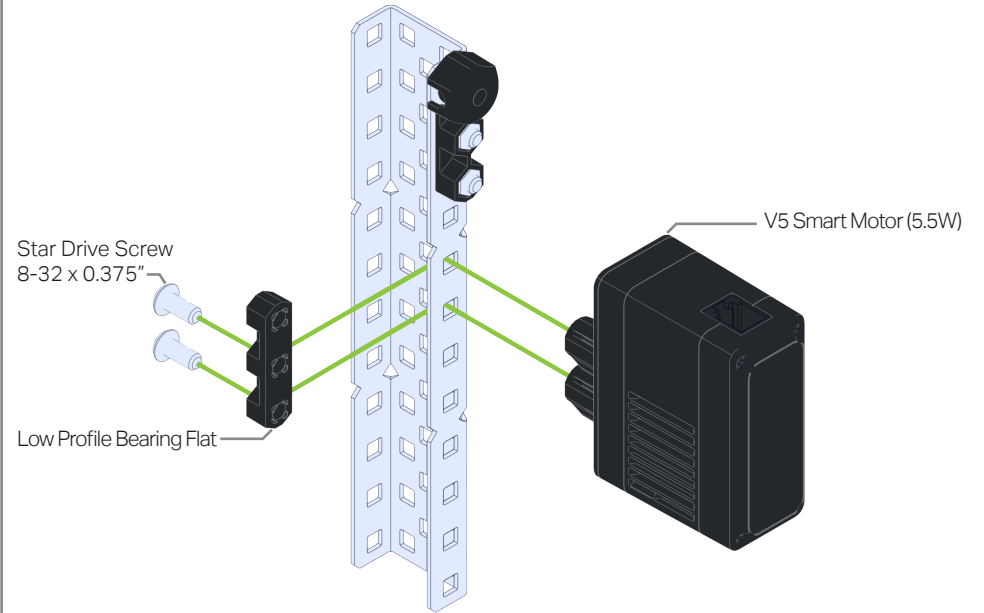

2x Star Drive Screw 8-32 x 0.375"



1x Low Profile Bearing Flat



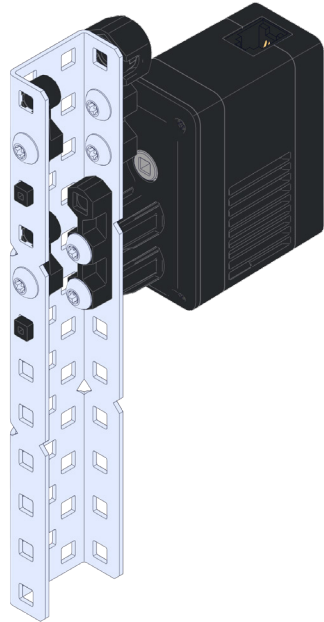
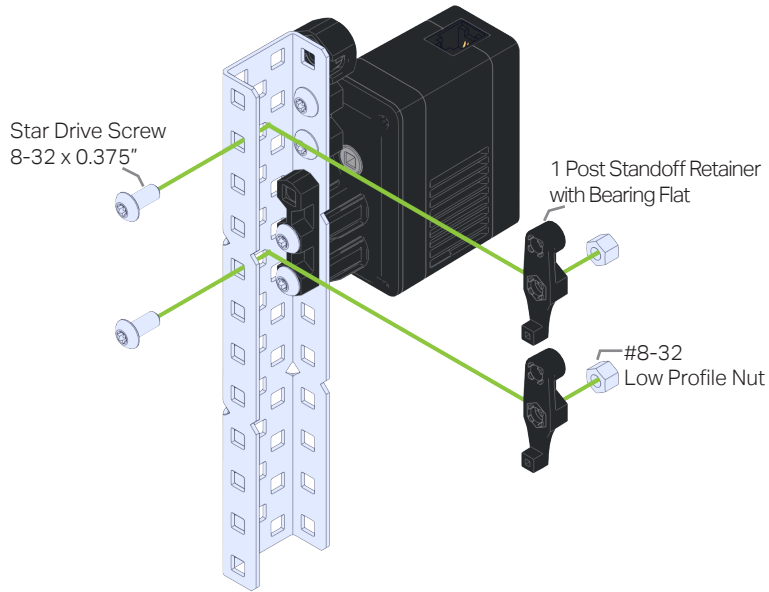

**2x** Star Drive Screw 8-32 x 0.375"



**2x** #8-32 Low Profile Nut



**2x** 1 Post Standoff Retainer with Bearing Flat

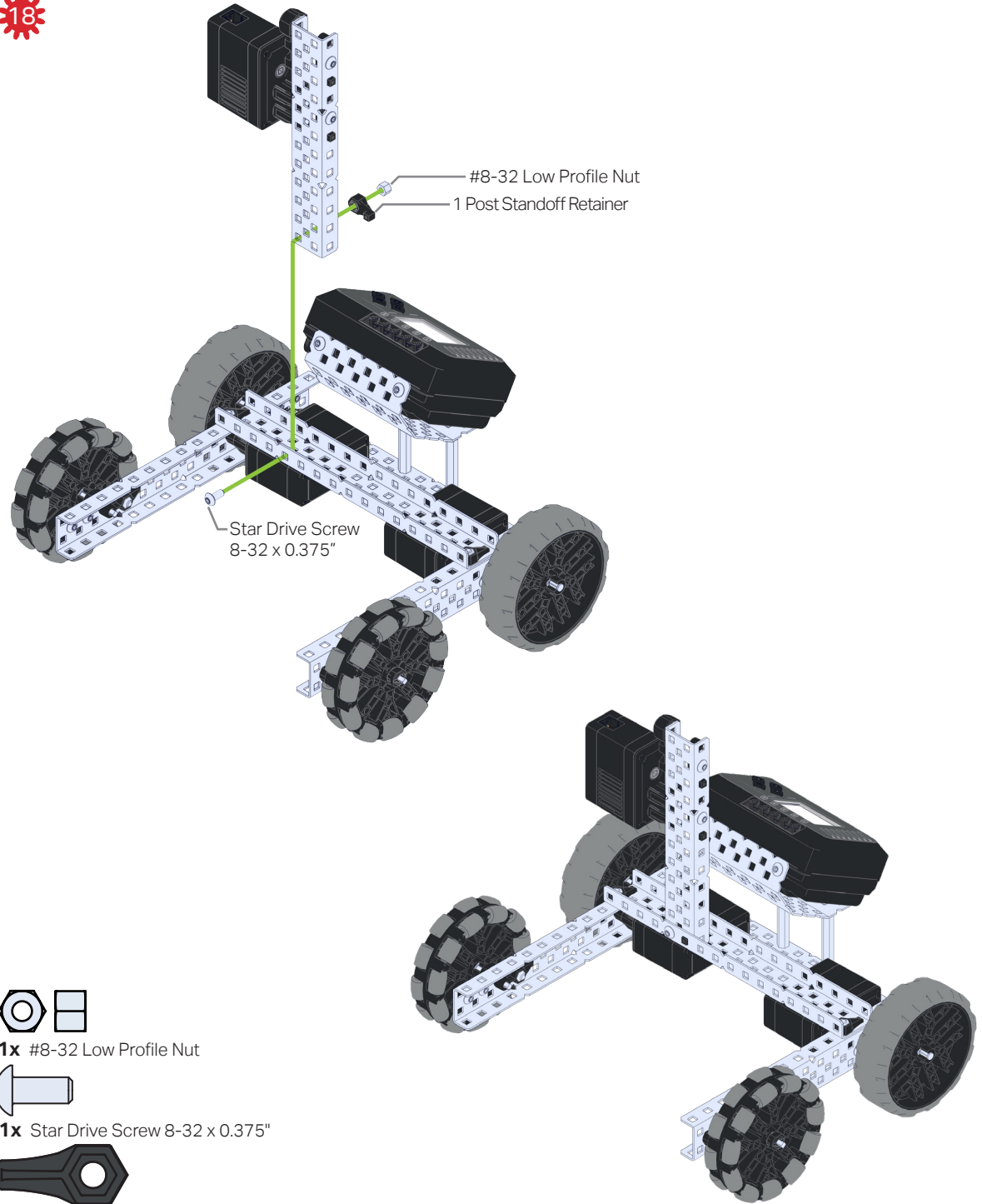

**1x** #8-32 Low Profile Nut



**1x** Star Drive Screw 8-32 x 0.375"



**1x** 1 Post Standoff Retainer

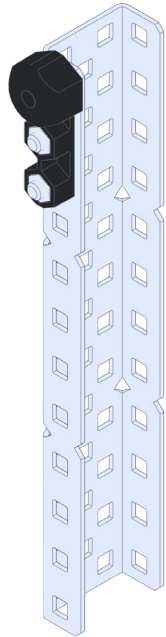
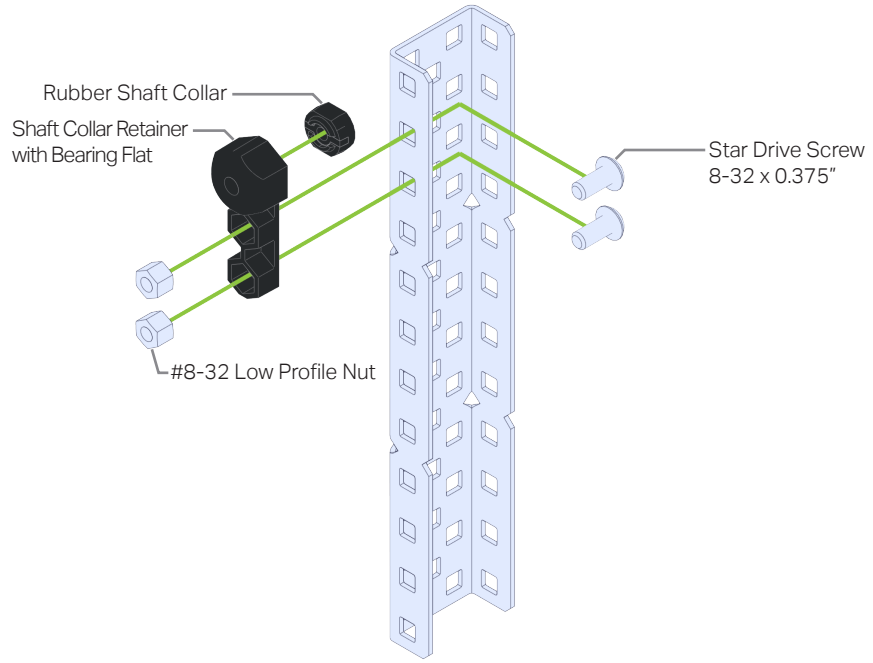

2x Star Drive Screw 8-32 x 0.375"



2x #8-32 Low Profile Nut



1x Rubber Shaft Collar



1x Shaft Collar Retainer with Bearing Flat

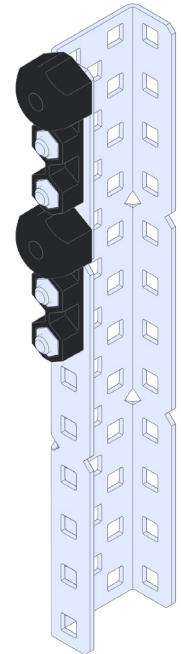
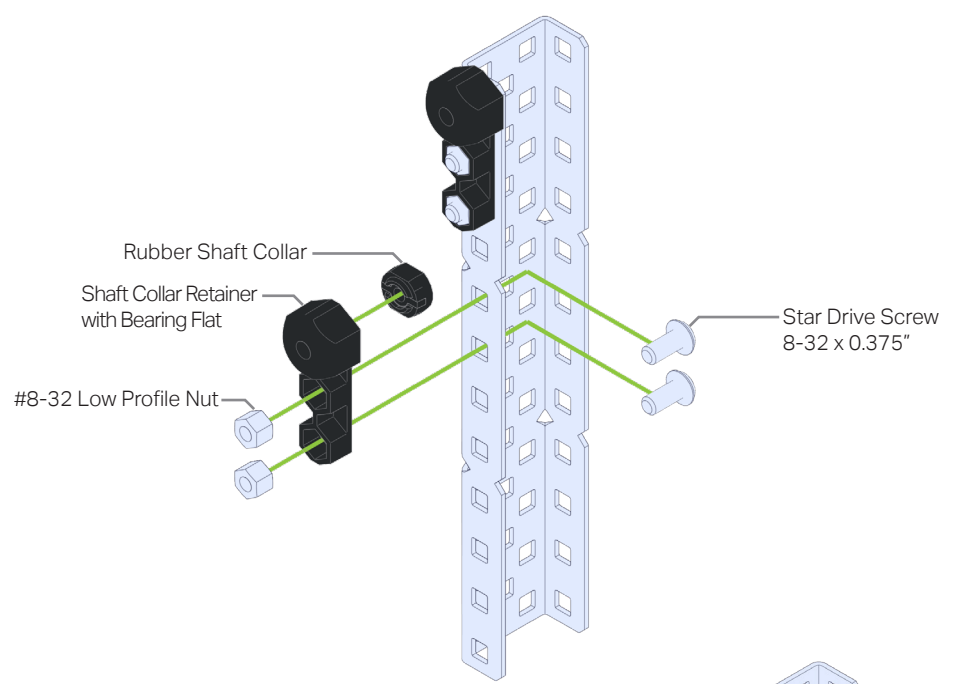

2x Star Drive Screw 8-32 x 0.375"



2x #8-32 Low Profile Nut



1x Rubber Shaft Collar



1x Shaft Collar Retainer with Bearing Flat

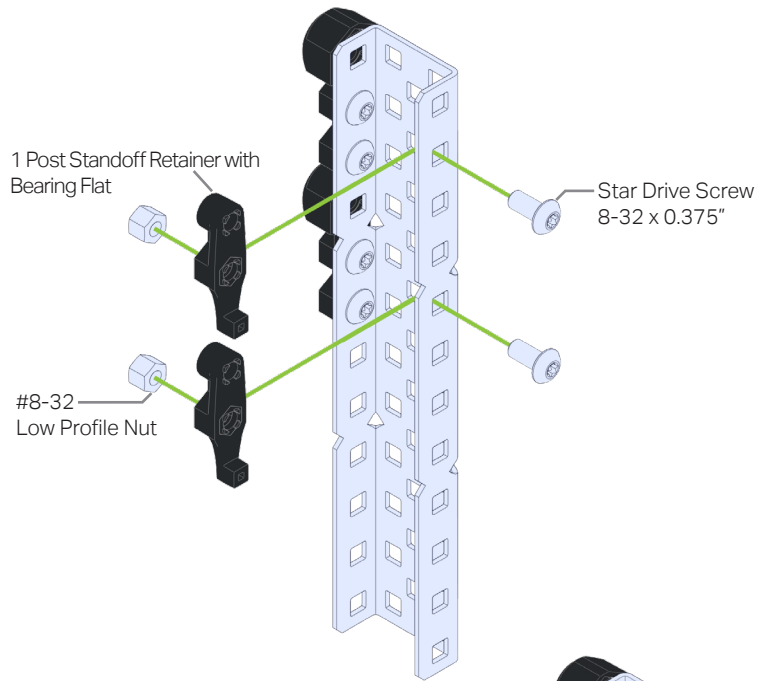

 2x Star Drive Screw 8-32 x 0.375"

 2x #8-32 Low Profile Nut

 2x 1 Post Standoff Retainer with Bearing Flat

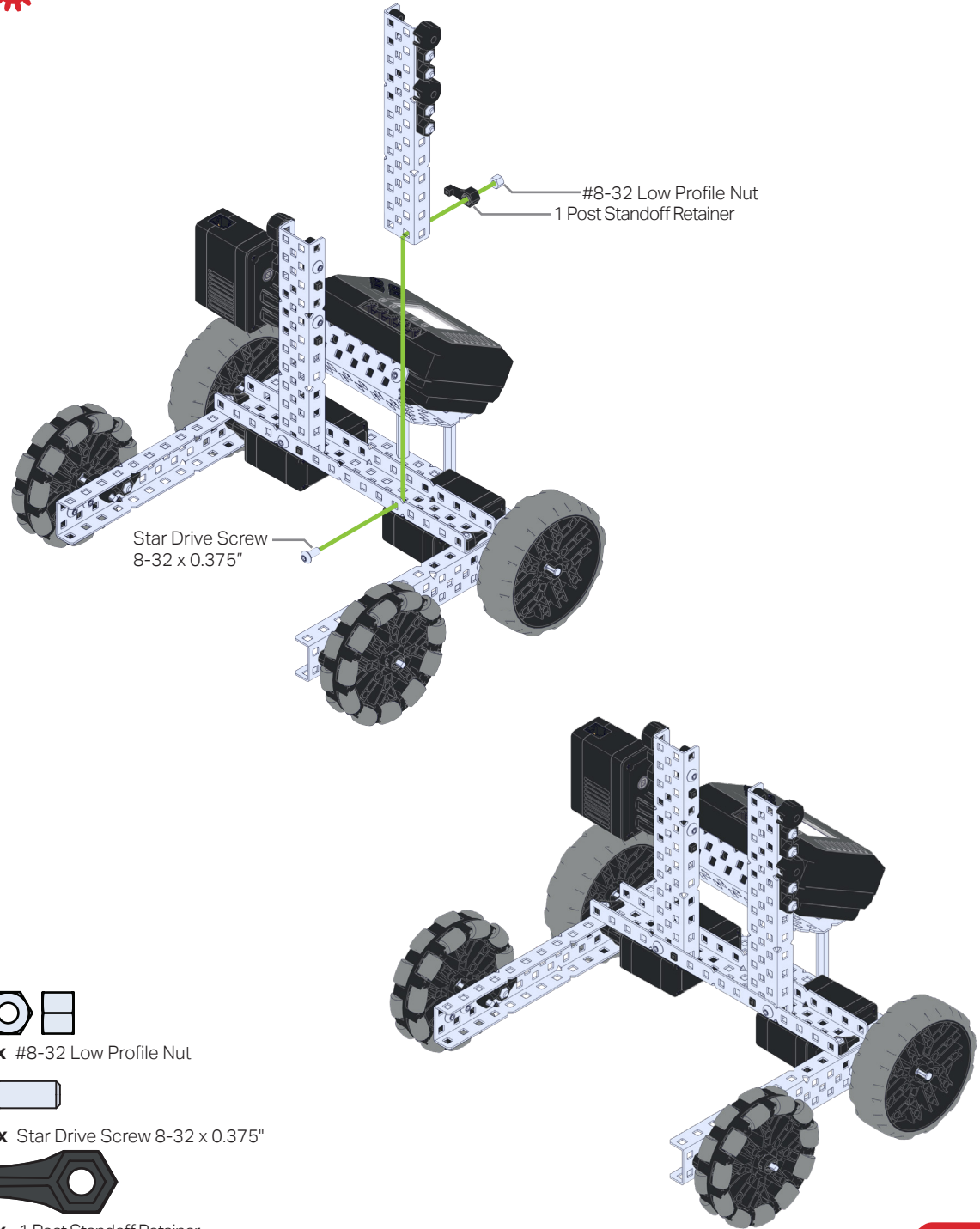
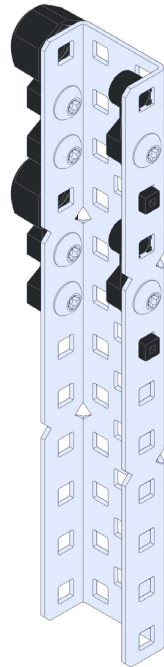

 1x #8-32 Low Profile Nut

 1x Star Drive Screw 8-32 x 0.375"

 1x 1 Post Standoff Retainer

23

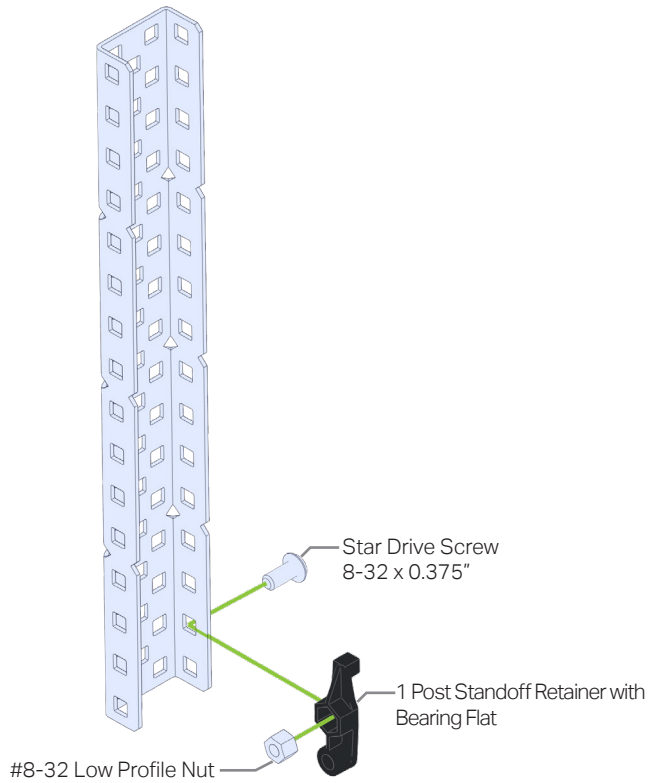

1x Star Drive Screw 8-32 x 0.375"



1x #8-32 Low Profile Nut



1x 1 Post Standoff Retainer with Bearing Flat

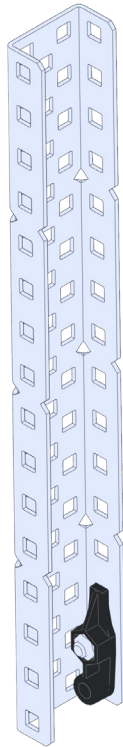

24

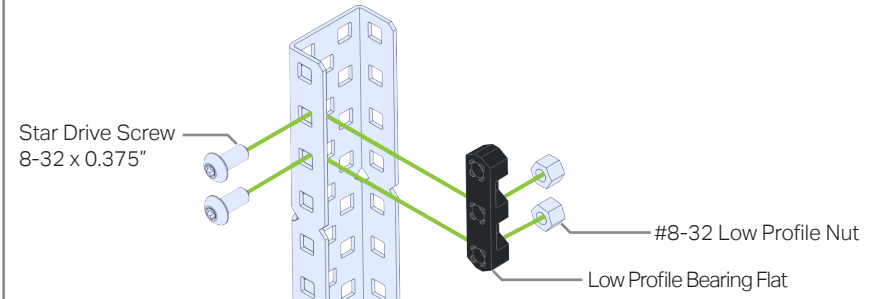

2x Star Drive Screw 8-32 x 0.375"



2x #8-32 Low Profile Nut



1x Low Profile Bearing Flat

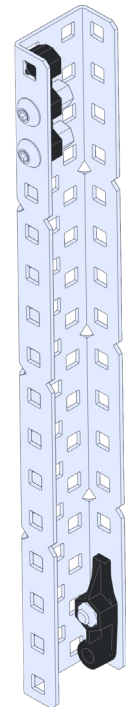



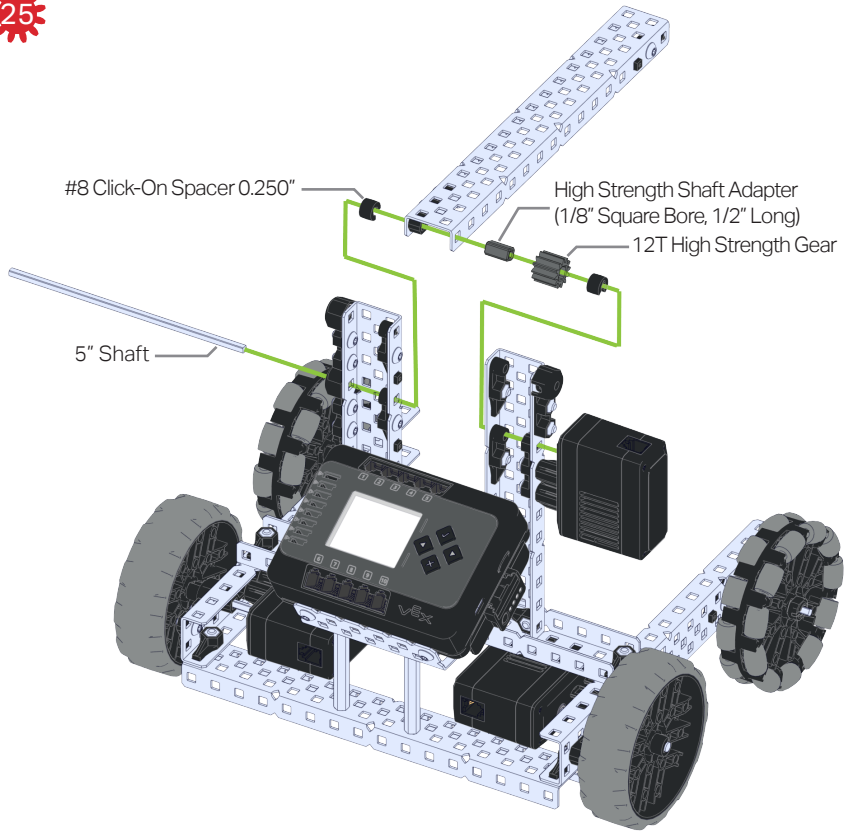

#8 Click-On Spacer 0.250"

High Strength Shaft Adapter  
(1/8" Square Bore, 1/2" Long)

12T High Strength Gear

5" Shaft

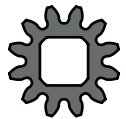

1x 12T High Strength Gear



2x #8 Click-On Spacer 0.250"



1x High Strength Shaft Adapter  
(1/8" Square Bore, 1/2" Long)

1x 5" Shaft

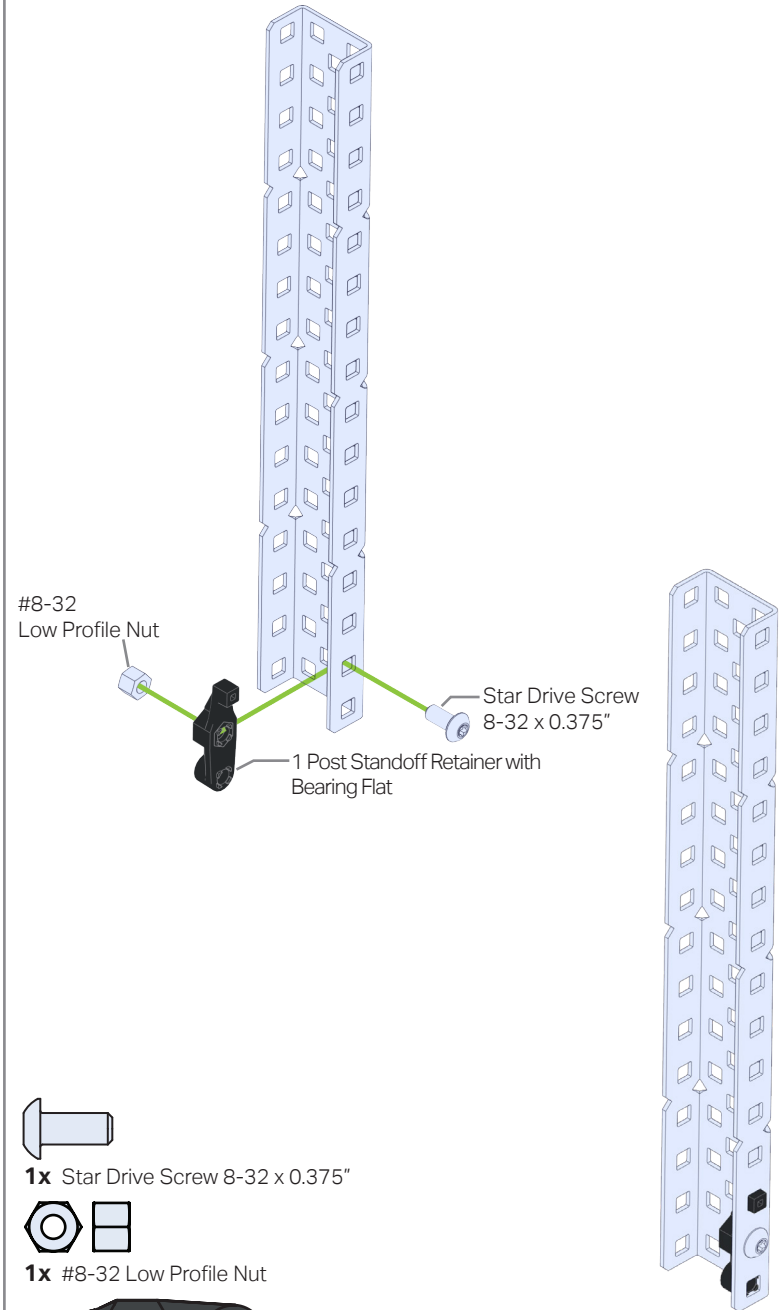
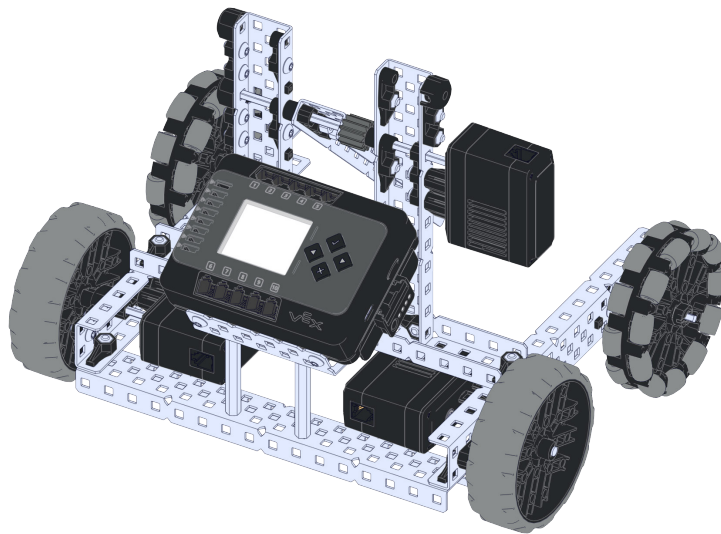

#8-32  
Low Profile Nut

Star Drive Screw  
8-32 x 0.375"

1 Post Standoff Retainer with  
Bearing Flat



1x Star Drive Screw 8-32 x 0.375"



1x #8-32 Low Profile Nut



1x 1 Post Standoff Retainer with Bearing Flat

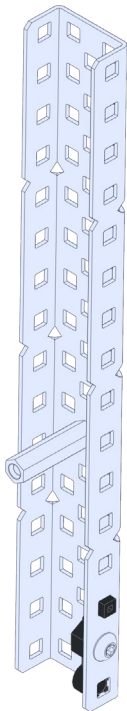
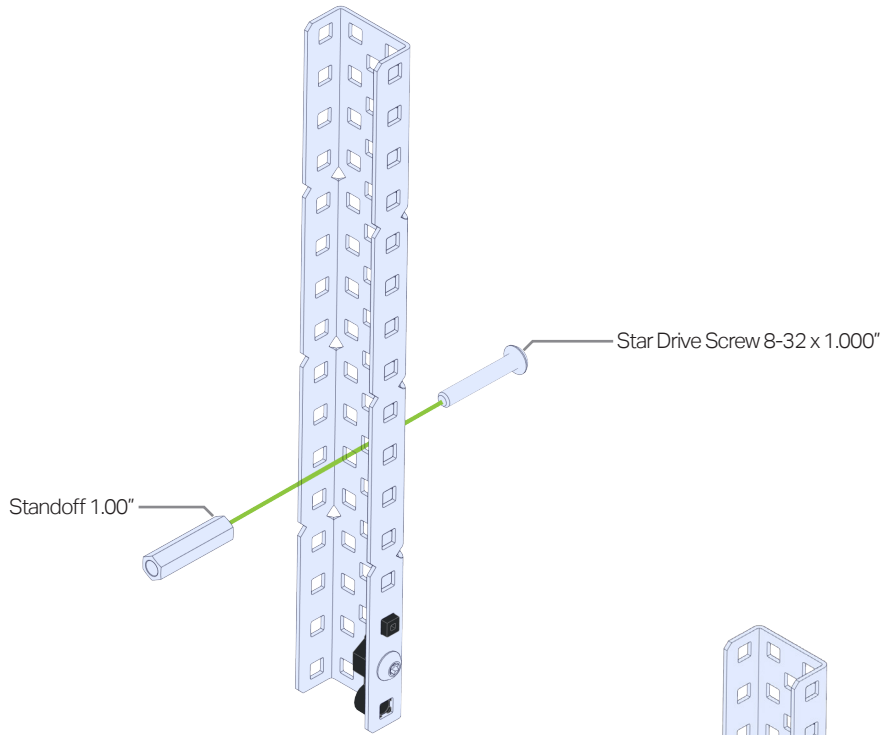

1x Star Drive Screw 8-32 x 1.000"



1x Standoff 1.00"

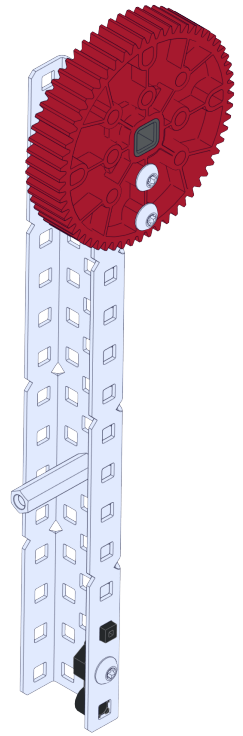
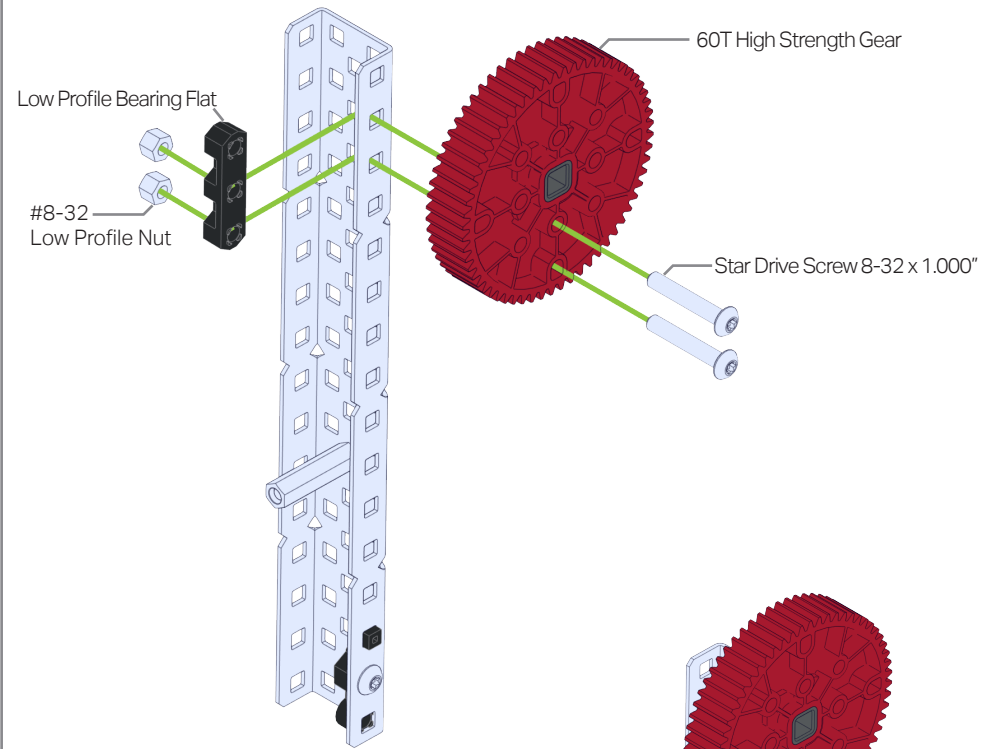

2x #8-32 Low Profile Nut



2x Star Drive Screw 8-32 x 1.000"



1x Low Profile Bearing Flat

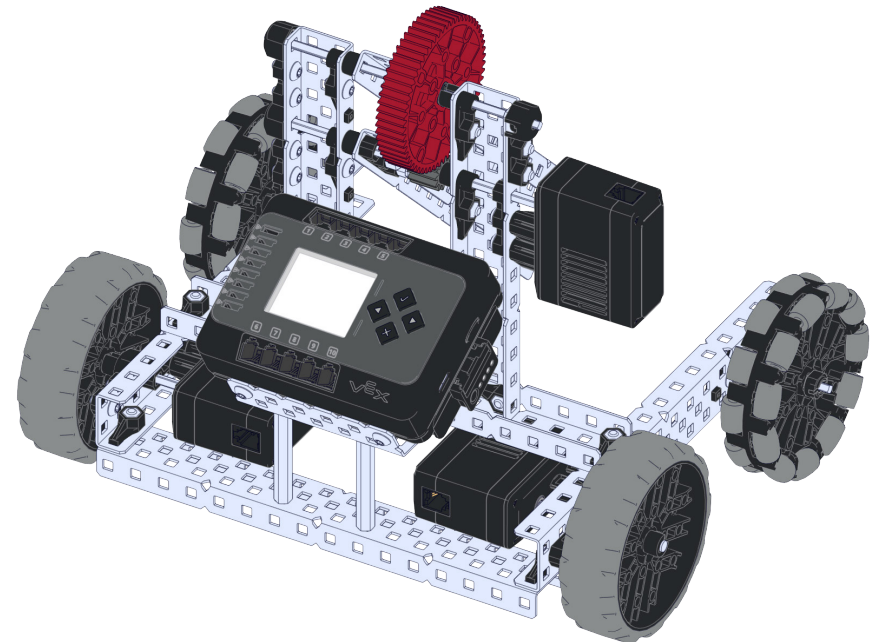
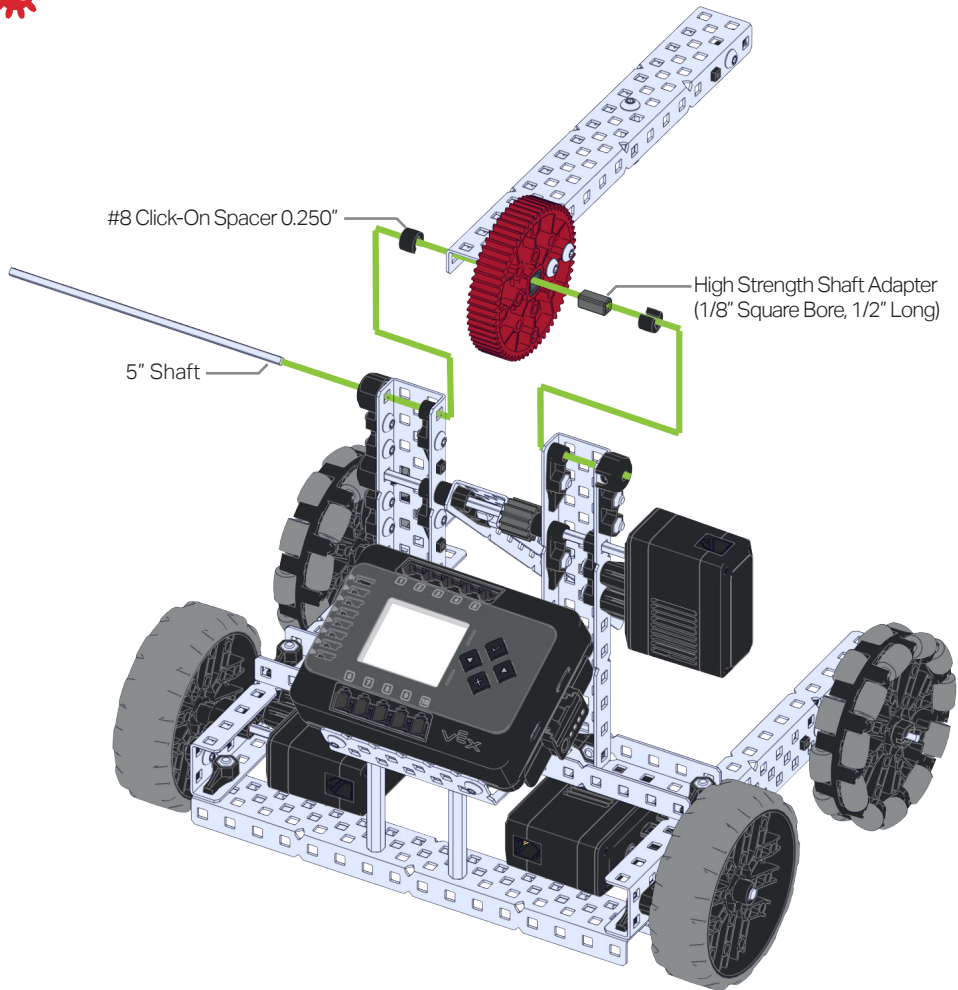

**2x** #8 Click-On Spacer 0.250"



**1x** High Strength Shaft Adapter  
(1/8" Square Bore, 1/2" Long)

**1x** 5" Shaft

30

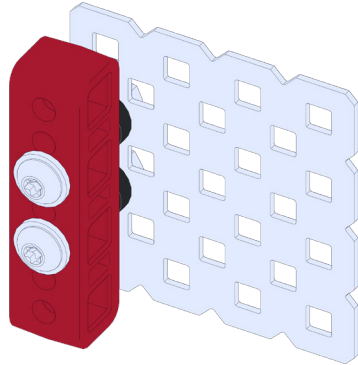
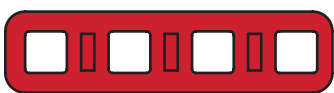
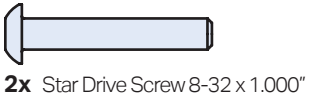
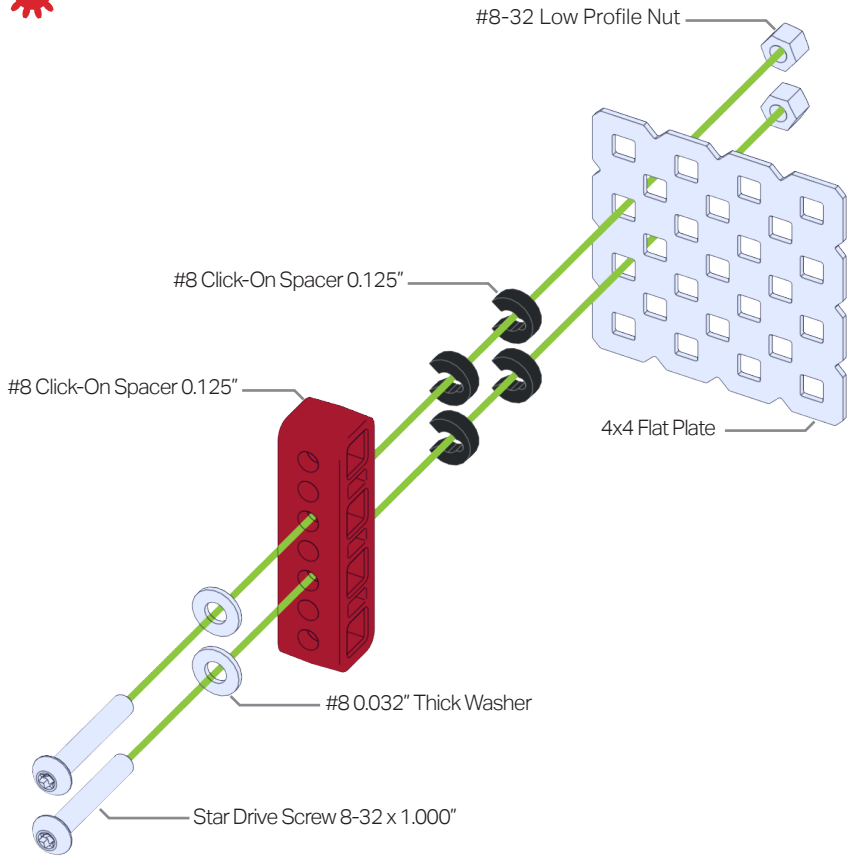

31

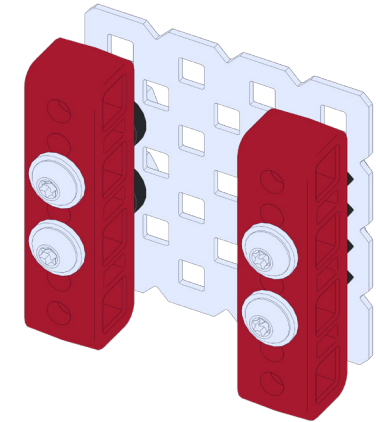
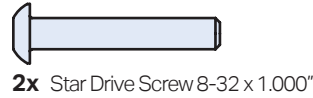
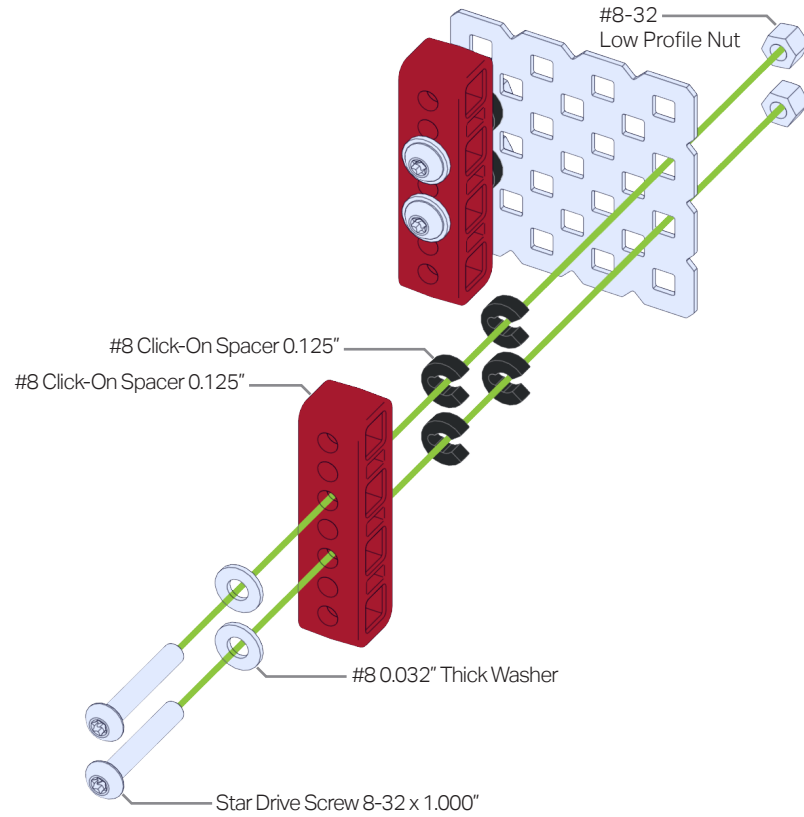



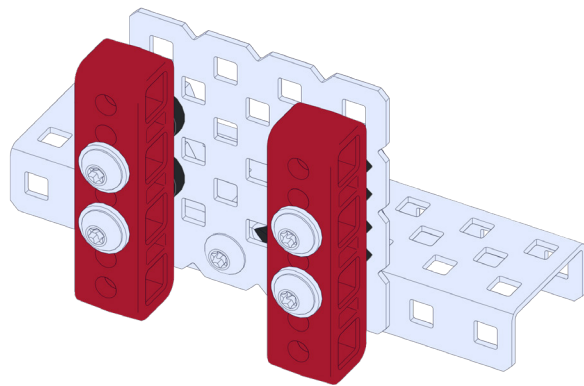
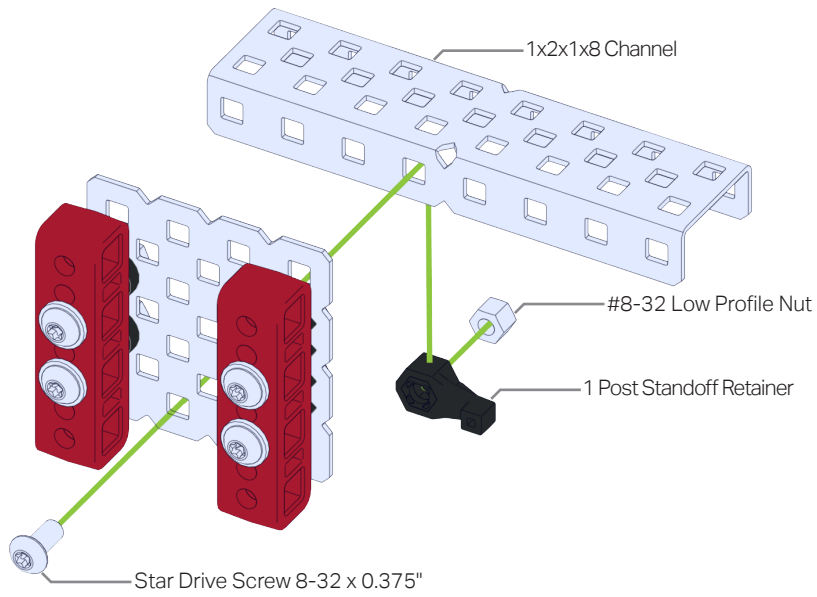

1x #8-32 Low Profile Nut



1x Star Drive Screw 8-32 x 0.375"



1x 1 Post Standoff Retainer

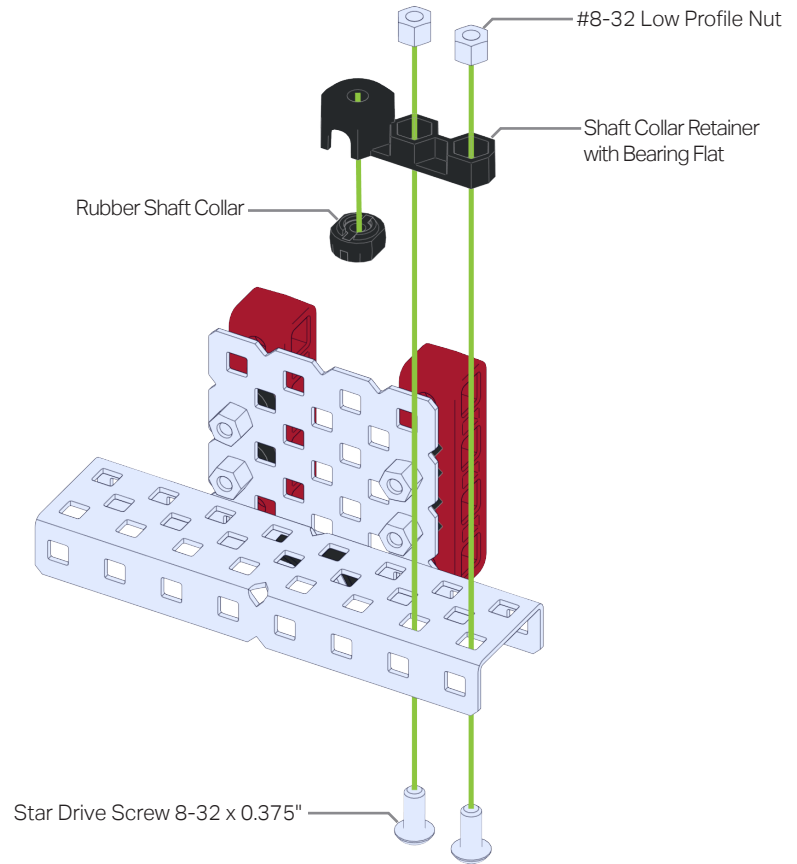

2x Star Drive Screw 8-32 x 0.375"



2x #8-32 Low Profile Nut



1x Rubber Shaft Collar



1x Shaft Collar Retainer with Bearing Flat

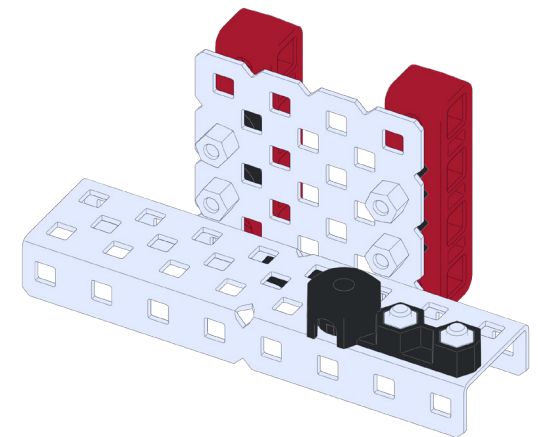

34

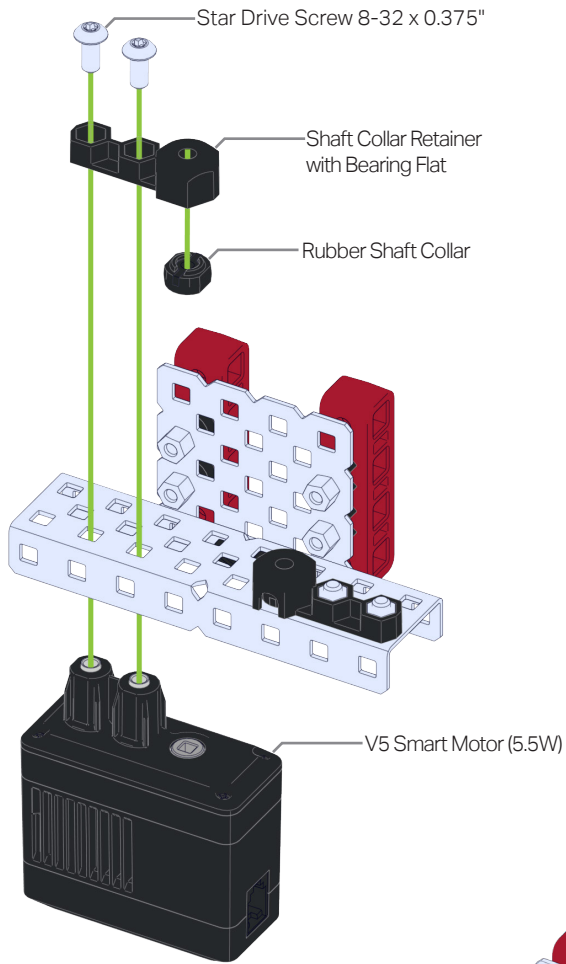

2x Star Drive Screw 8-32 x 0.375"



1x Rubber Shaft Collar



1x Shaft Collar Retainer with Bearing Flat

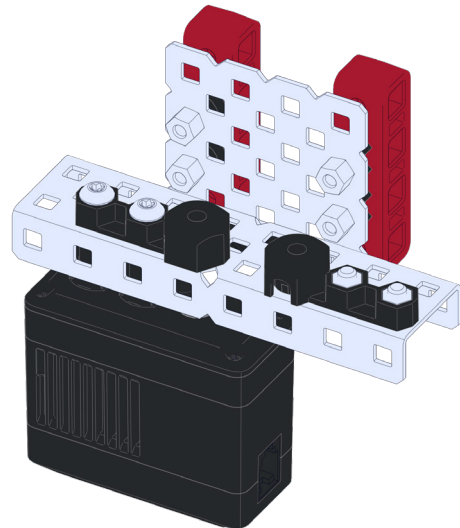

35

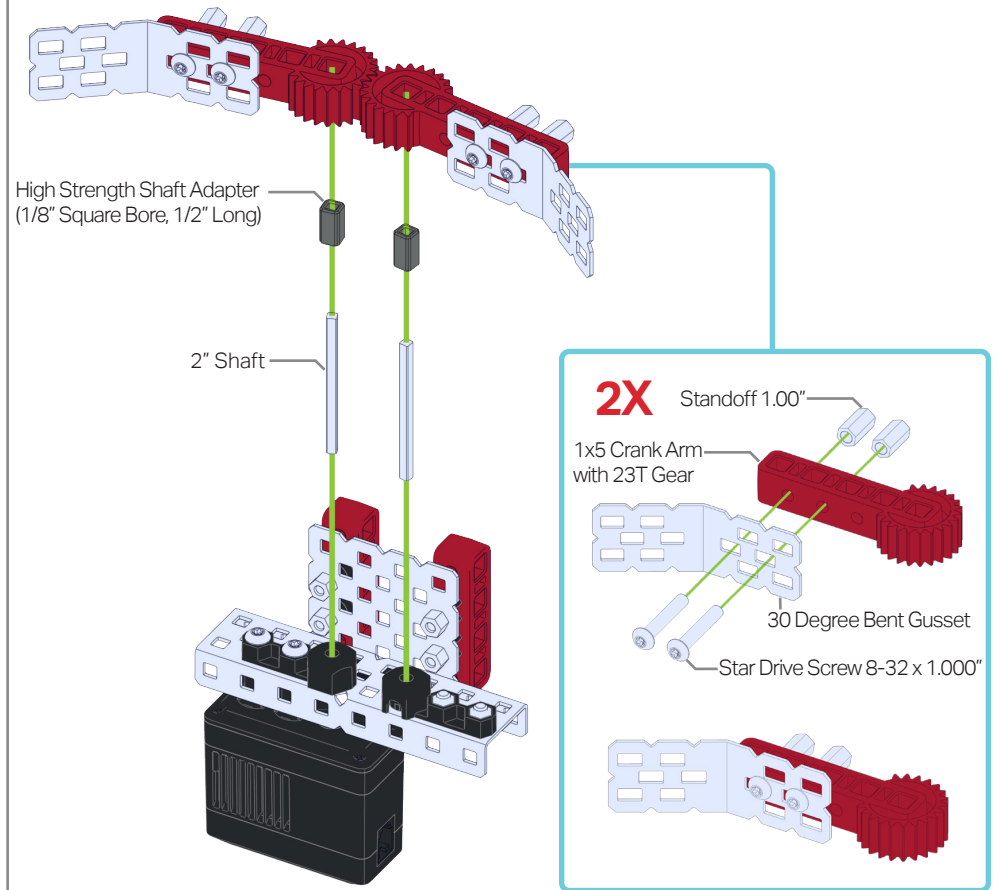

2x High Strength Shaft Adapter (1/8" Square Bore, 1/2" Long)

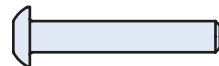

4x Star Drive Screw 8-32 x 1.000"



4x Standoff 1.00"



2x 2" Shaft

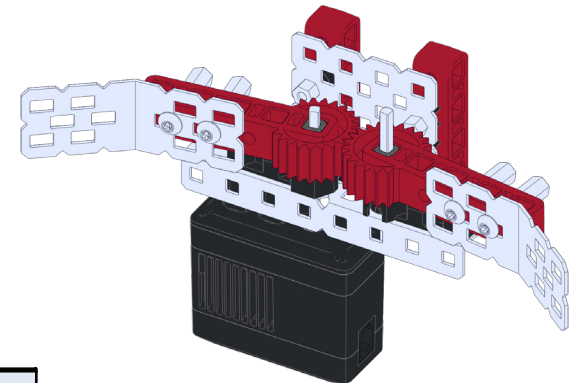

36

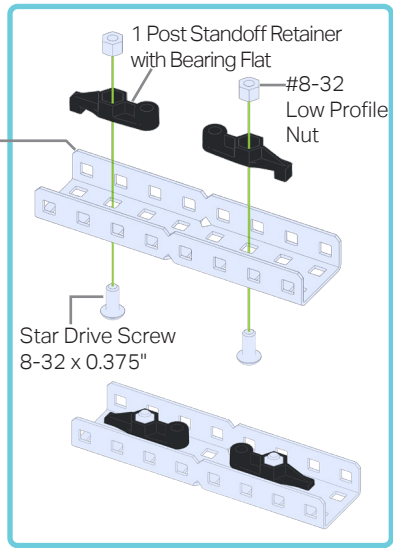
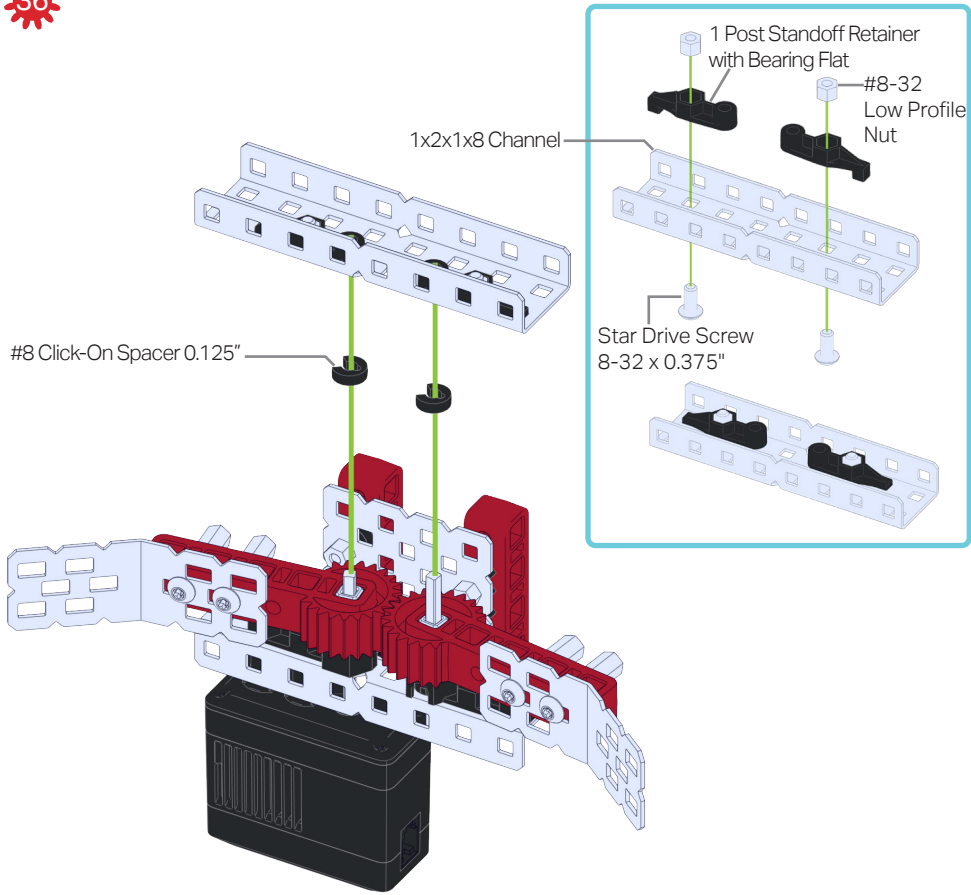

2x #8 Click-On Spacer 0.125"



2x Star Drive Screw 8-32 x 0.375"



2x #8-32 Low Profile Nut



2x 1 Post Standoff Retainer with Bearing Flat

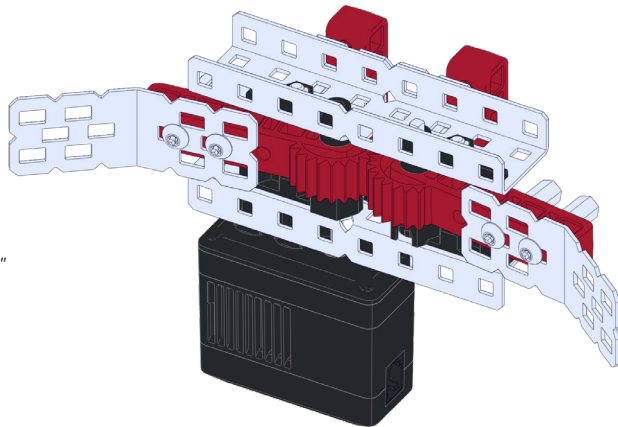

37

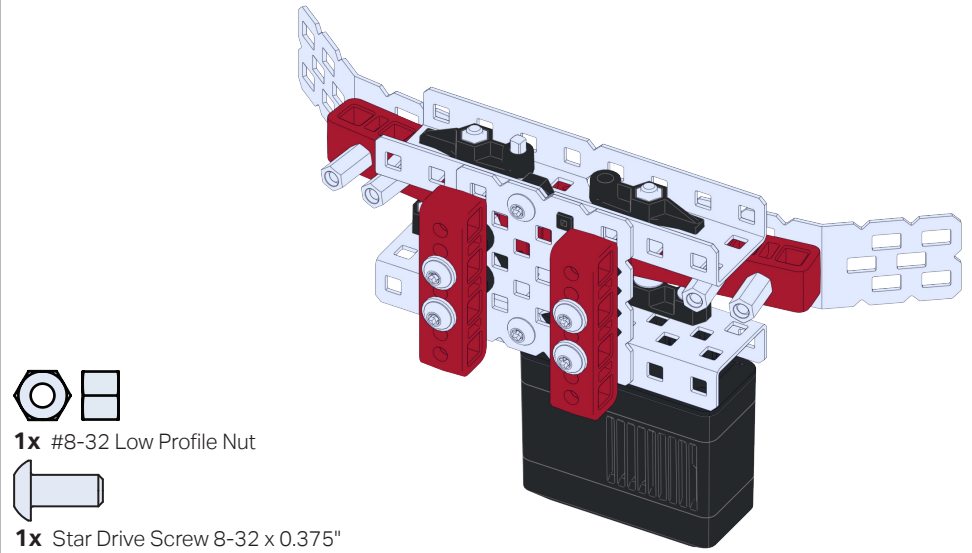
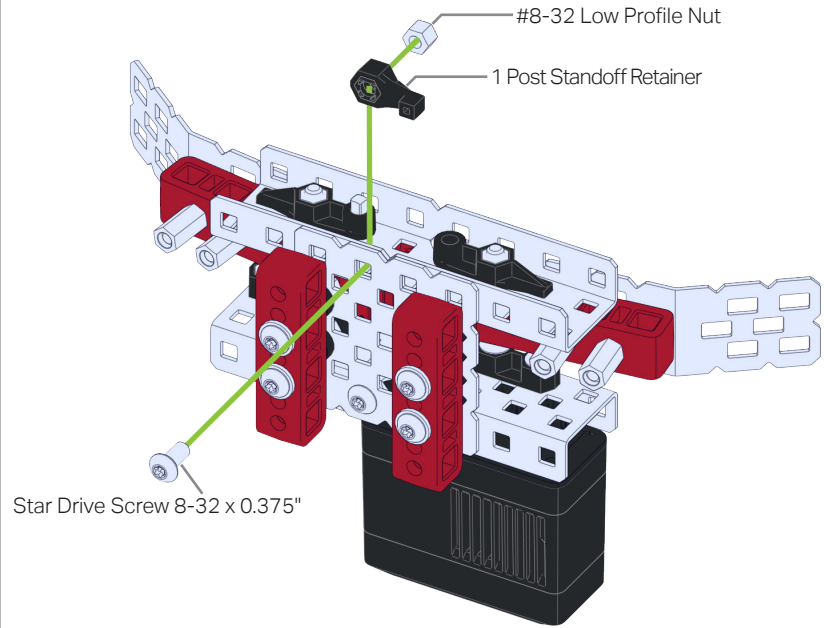

1x #8-32 Low Profile Nut



1x Star Drive Screw 8-32 x 0.375"



1x 1 Post Standoff Retainer

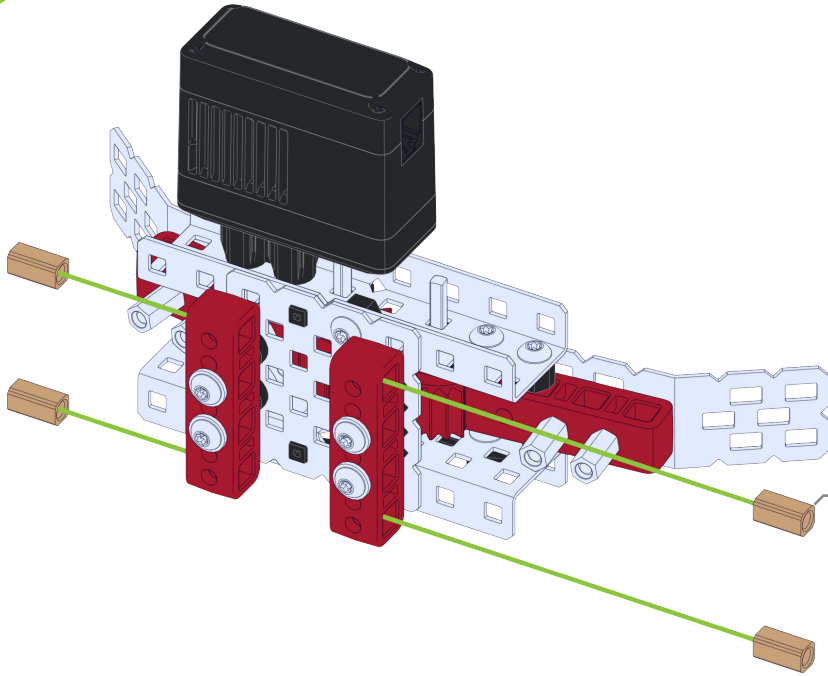

High Strength Shaft Adapter  
(#8 Round Bore, 1/2" Long)

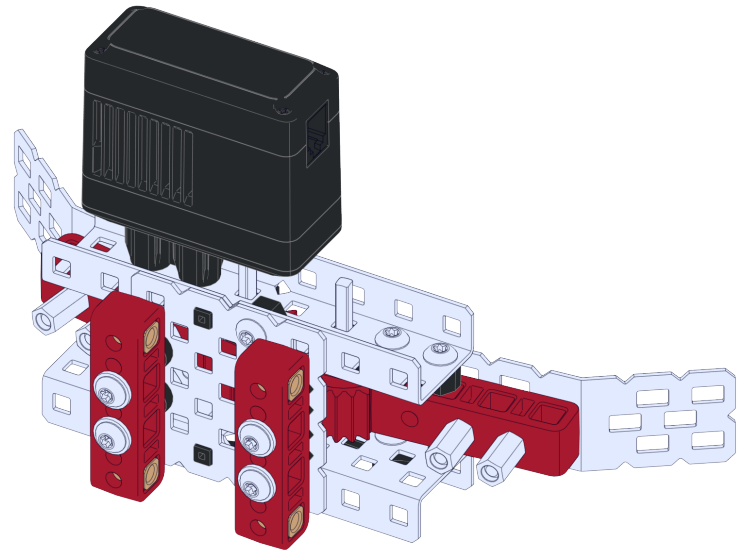

**4x** High Strength Shaft Adapter  
(#8 Round Bore, 1/2" Long)

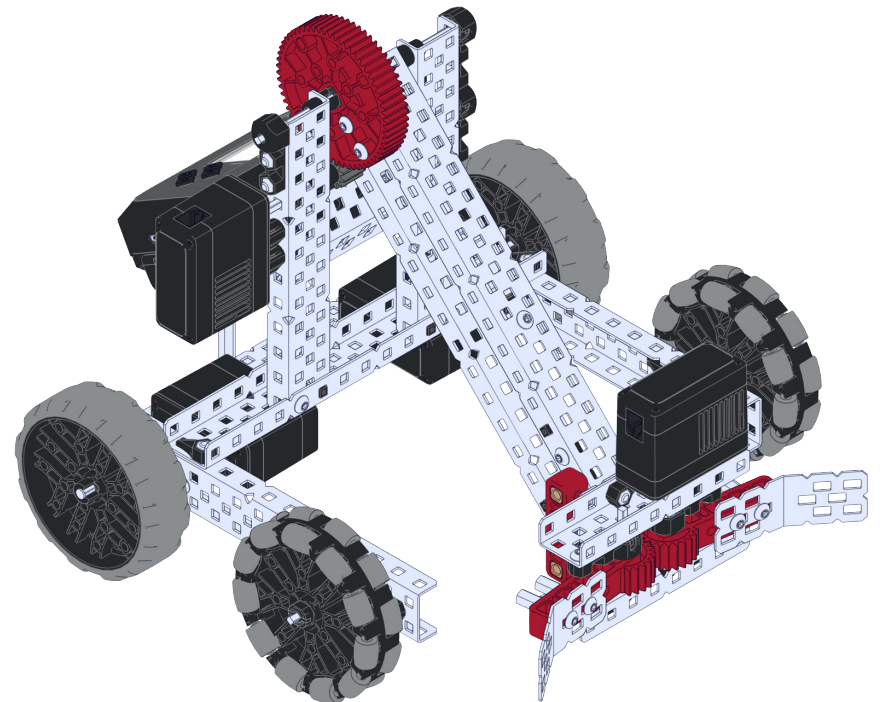
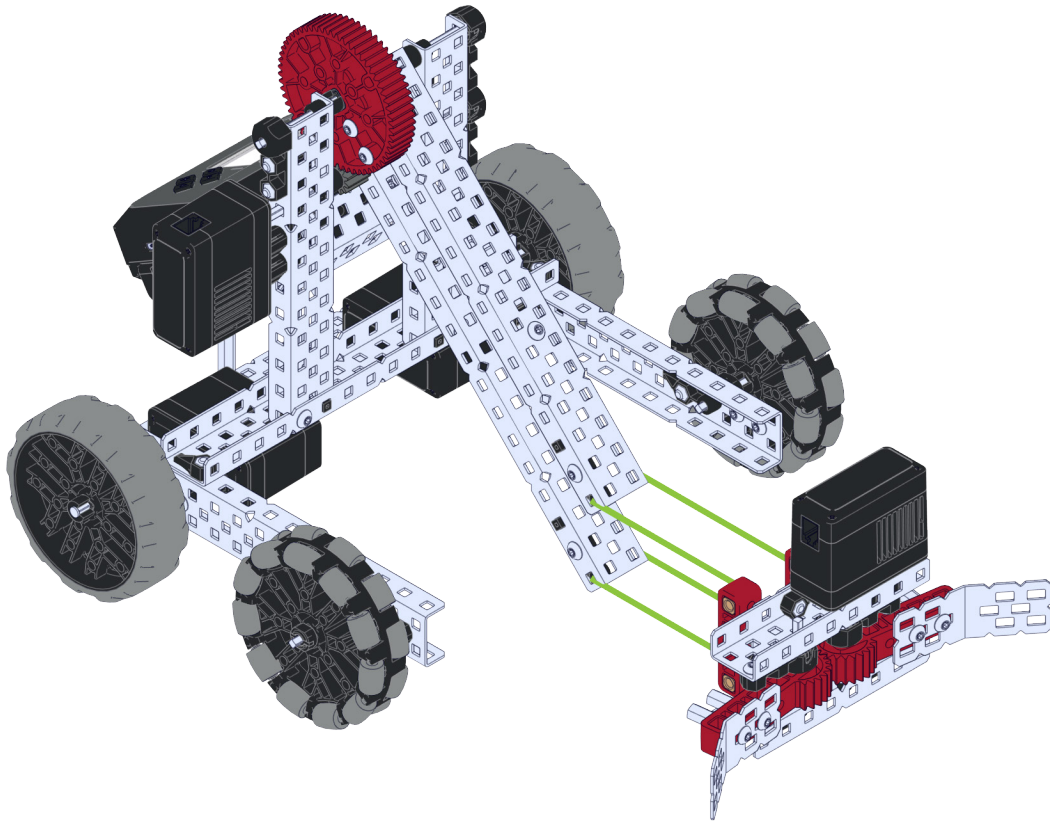



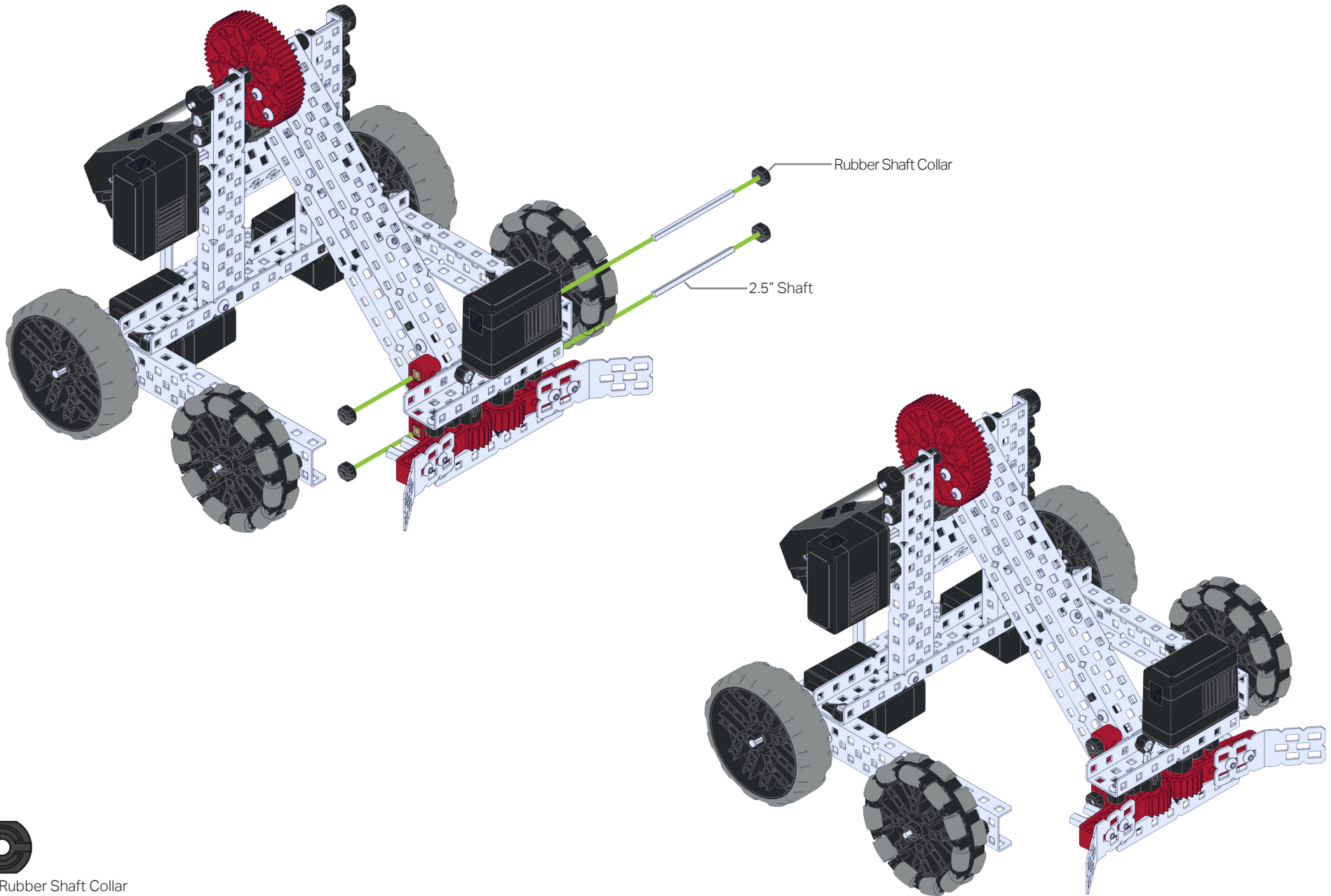

4x Rubber Shaft Collar



2x 2.5" Shaft

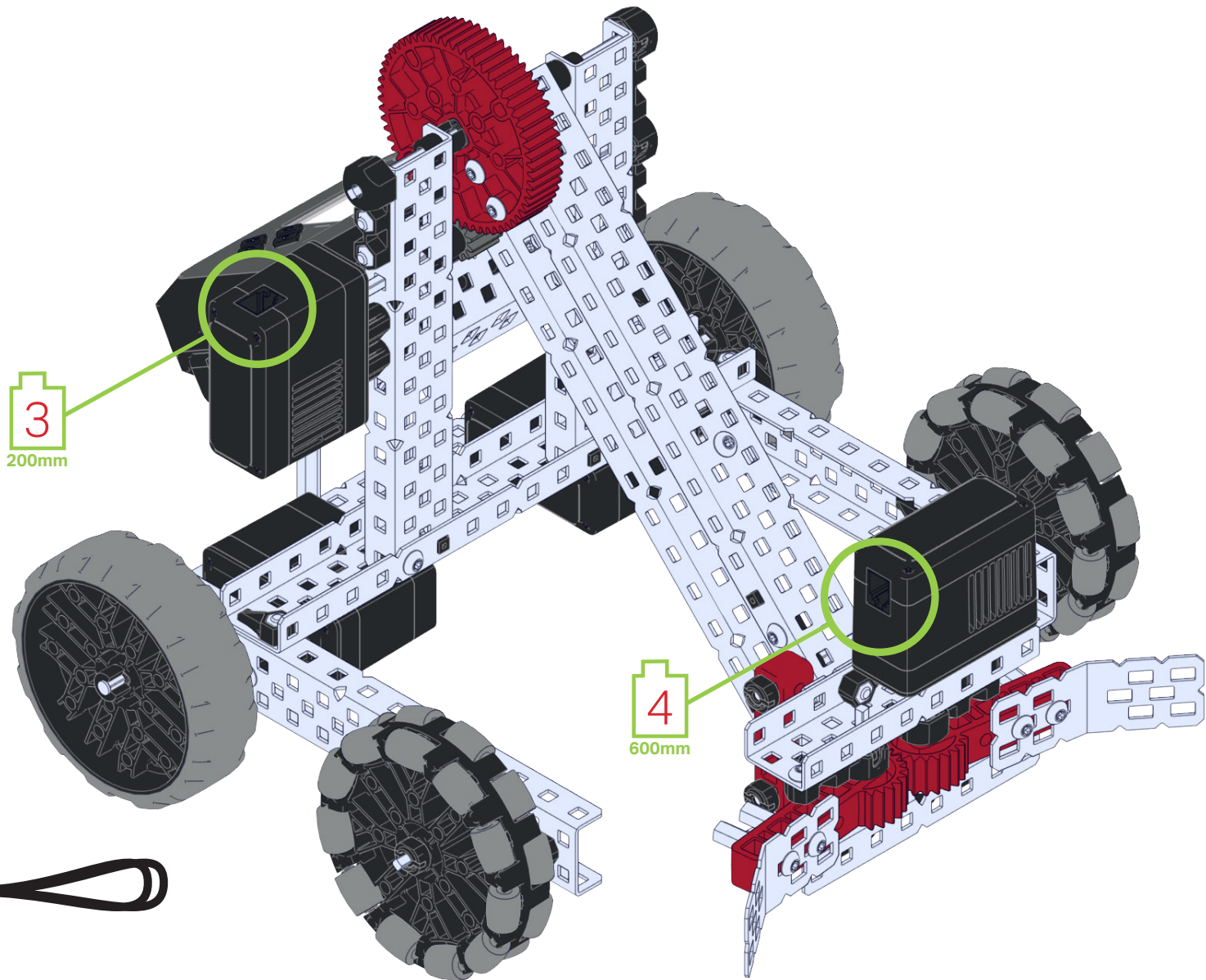

1x 200mm Smart Cable

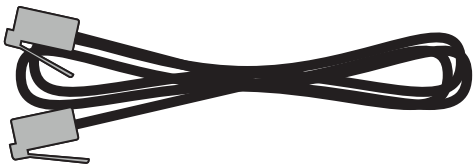

1x 600mm Smart Cable

# EXP Clawbot Build Instructions

280-7735-752 Rev3



Custom manufactured in China for Innovation First Trading SARL. Distributed in the U.S.A. by VEX Robotics, Inc., 6725 W. FM 1570, Greenville, TX 75402, U.S.A. Distributed in Europe by Innovation First Trading SARL, 21b rue Gabriel Lippmann, L-5365 Munsbach, Luxembourg +352 27 86 04 87. Distributed in Canada by / Distribué au Canada par / Innovation First Trading, Inc., 6725 W. FM 1570, Greenville, TX 75402, U.S.A. ©2018 VEX Robotics, Inc. All rights reserved. Tous droits réservés.